

Experimental Methods in Plasma Physics

Sam Cohen, PPPL

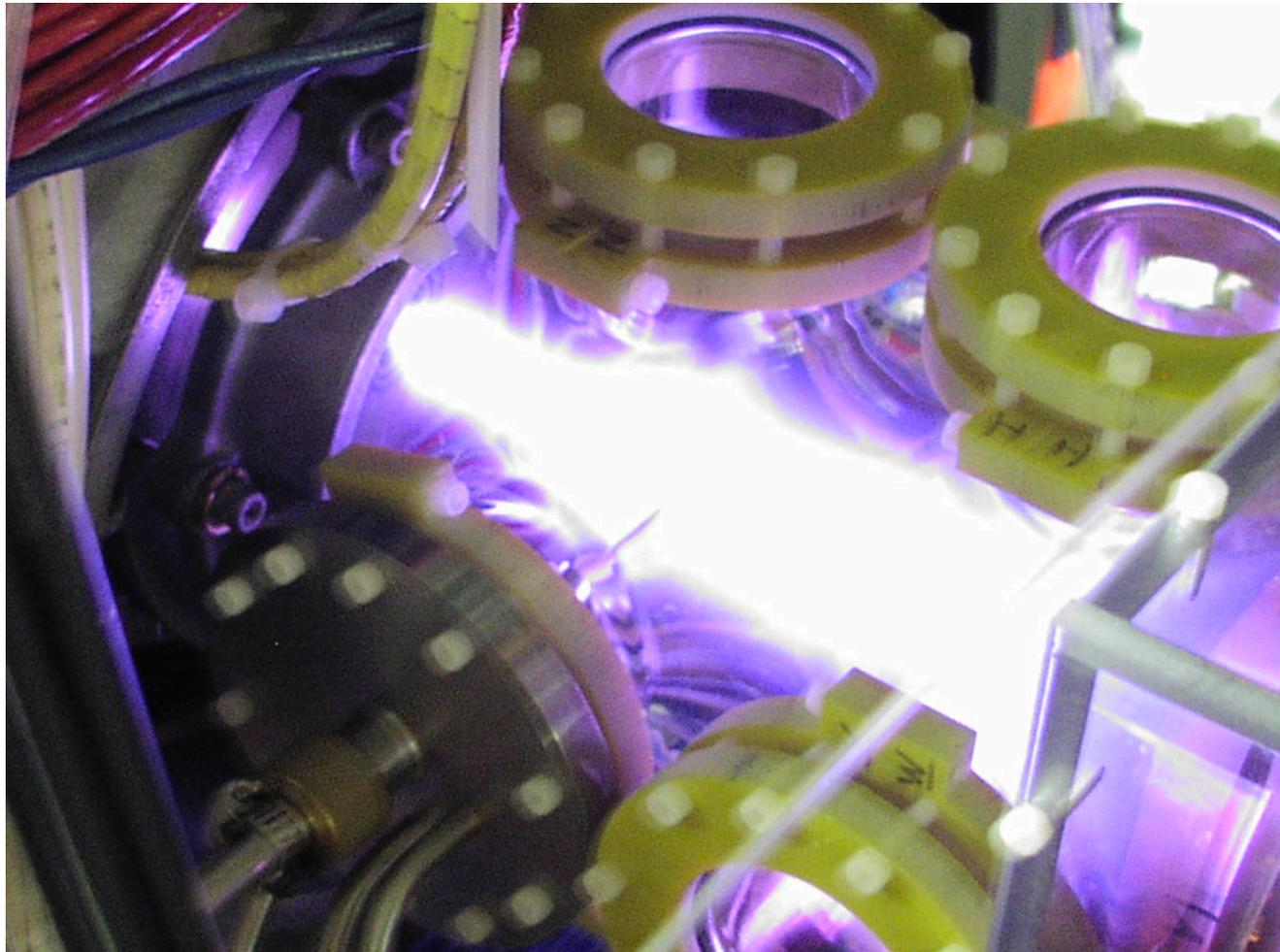

Experiments and lab partners for Wednesday & Thursday afternoons

If you don't see your name on this list and want to do an experiment,
see DeeDee after the lecture.

Tuesday, June 9, 2015

<u>Paschen (Mata)</u>	<u>Interferometer (Kraus)</u>	<u>Langmuir (Matteucci)</u>	<u>Chaos (Coogan)</u>
Amanda Lewis	Cara Bagley	Hanna Schamis	Justin Wberski
Ansel Dow	Ellie Forbes	Ian Stewart	Leandro Foxque
Ben Israeli	Gregg Willcox	Jacob Maddox	Michael McNulty

Wednesday, June 10, 2015

<u>Paschen (Jandovitz)</u>	<u>Interferometer (Swanson)</u>	<u>Langmuir (Schwartz)</u>	<u>Chaos (Dong)</u>
Emily Ho	Brandon Lee	Kameron Hansen	Matthew Capella
Evan Peters	Joseph Milliano	Emma Williard	Horace Zhang
Hannah Hoffman	Victoria Riso	Samantha Guerra	Bolton Ferda



Mathematics is the *Queen* of Science

Paschen

from
SCIENCE AND HYPOTHESIS

by
HENRI POINCARÉ

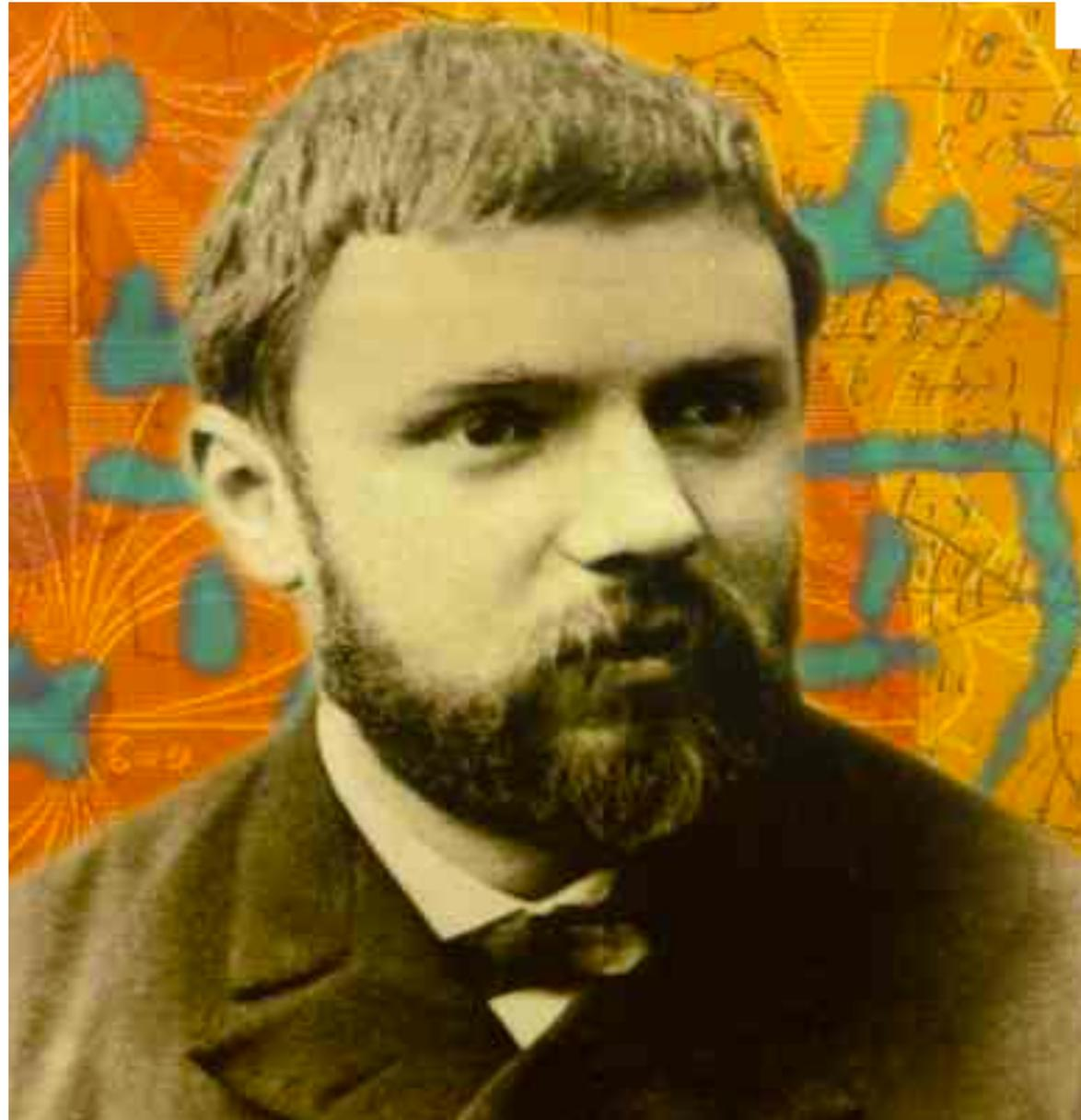

Making plasma

- Large or small
- Hot or cold
- Dense or tenuous
- Pulsed or steady state
- Near or far
- Typical or unique
- Stable or unstable
- Controlled or not

A lazy (or smart) person's way to make plasma

The Universe

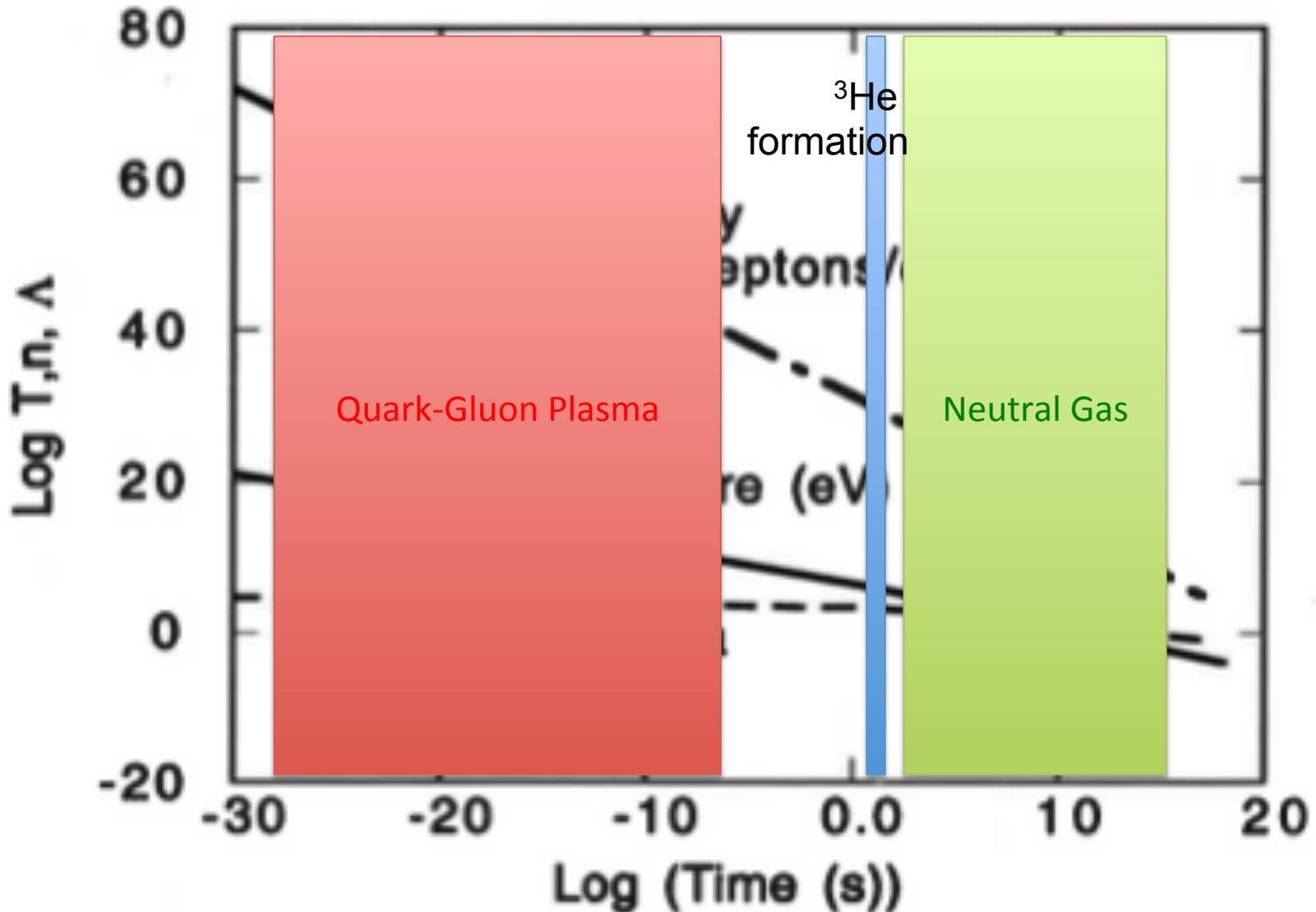

Time without end: Physics and biology in an open universe*

Freeman J. Dyson

Institute for Advanced Study, Princeton, New Jersey 08540

Quantitative estimates are derived for three classes of phenomena that may occur in an open cosmological model of Friedmann type. (1) Normal physical processes taking place with very long time-scales. (2) Biological processes that will result if life adapts itself to low ambient temperatures according to a postulated scaling law. (3) Communication by radio between life forms existing in different parts of the universe. The general conclusion of the analysis is that an open universe need not evolve into a state of permanent quiescence. Life and communication can continue for ever, utilizing a finite store of energy, if the assumed scaling laws are valid.

CONTENTS

Lecture I. Philosophy	447
Lecture II. Physics	449
A. Stellar evolution	450
B. Detachment of planets from stars	450
C. Detachment of stars from galaxies	450
D. Decay of orbits by gravitational radiation	451
E. Decay of black holes by the Hawking process	451
F. Matter is liquid at zero temperature	451
G. All matter decays to iron	452
H. Collapse of iron star to neutron star	452
I. Collapse of ordinary matter to black hole	452
Lecture III. Biology	453
Lecture IV. Communication	457

3 °K radiation background (Penzias and Wilson, 1965) was to force all of us to take seriously the idea that there was an early universe."

Thanks to Penzias and Wilson, Weinberg and others, the study of the beginning of the universe is now respectable. Professional physicists who investigate the first three minutes or the first microsecond no longer need to feel shy when they talk about their work. But the end of the universe is another matter. I have searched the literature for papers about the end of the universe and found very few (Rees, 1969; Davies, 1973; Islam, 1977 and 1979; Barrow and Tipler, 1978). This list is certainly not complete. But the interesting thing about these papers is that they are

TABLE I. Summary of time scales.

Closed Universe	
Total duration	10^{11} yr
Open Universe	
Low-mass stars cool off	10^{14} yr
Planets detached from stars	10^{15} yr
Stars detached from galaxies	10^{19} yr
Decay of orbits by gravitational radiation	10^{20} yr
Decay of black holes by Hawking process	10^{64} yr
Matter liquid at zero temperature	10^{65} yr
All matter decays to iron	10^{1500} yr
Collapse of ordinary matter to black hole [alternative (ii)]	$10^{10^{26}}$ yr
Collapse of stars to neutron stars or black holes [alternative (iv)]	$10^{10^{76}}$ yr

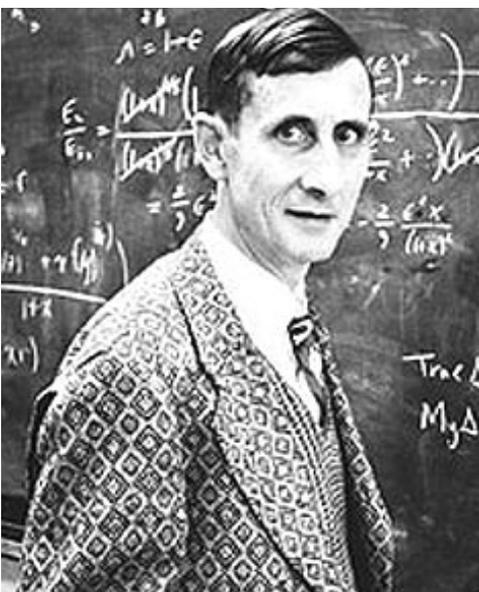

Methods to make plasma: 1) heat

A plasma

$$n \frac{4\pi}{3} \lambda_D^3 = \Lambda \sim 2 \times 10^9 T_e^{3/2} / n_e^{1/2} > 1 \quad (T_e \text{ in eV, } n_e \text{ in cm}^{-3})$$

i.e., hot may be dense
cold must be tenuous

What is the lower limit on T_e ?

- $\omega_{pe} > \omega_{coll.} \quad e^- + \text{neutral}$
i.e., few "other types of" collisions which might destroy collective behavior

What types of collisions can destroy collective motion?

- $\tau_{recom} > \tau_{plasma}$

Electromagnetic interactions can cause ionization

Externally applied dc, ac fields
electron and ion motion

Collisions with neutral, excited or charged
particles

coronal equilibrium

thermal equilibrium (detailed balance)

Externally applied rf, μ wave fields
electron ~~and ion~~ motion

Photons

resonant photons

high energy photons

2) Electron impact: often a first step

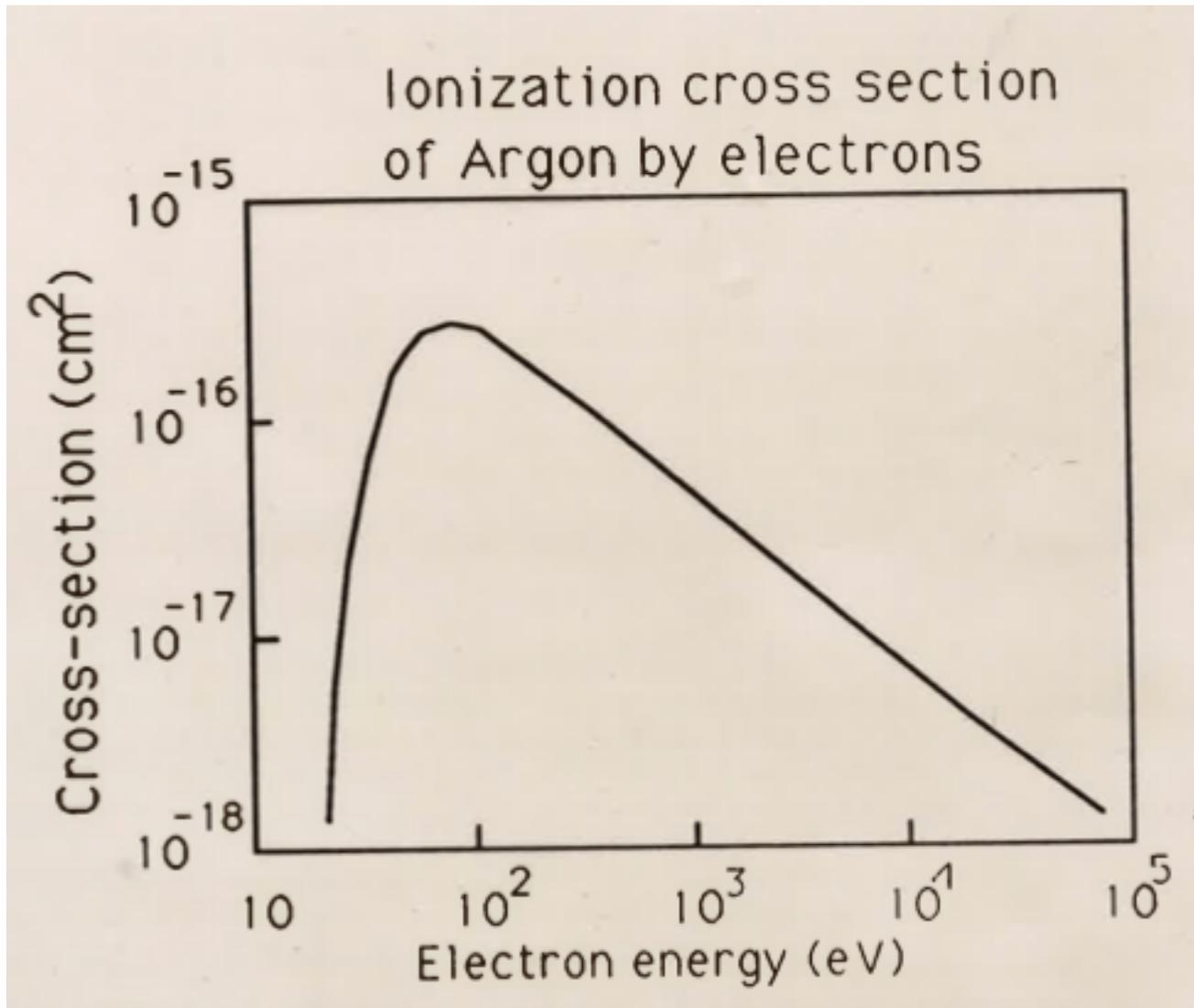

3) Another way to ionize: Compton scattering

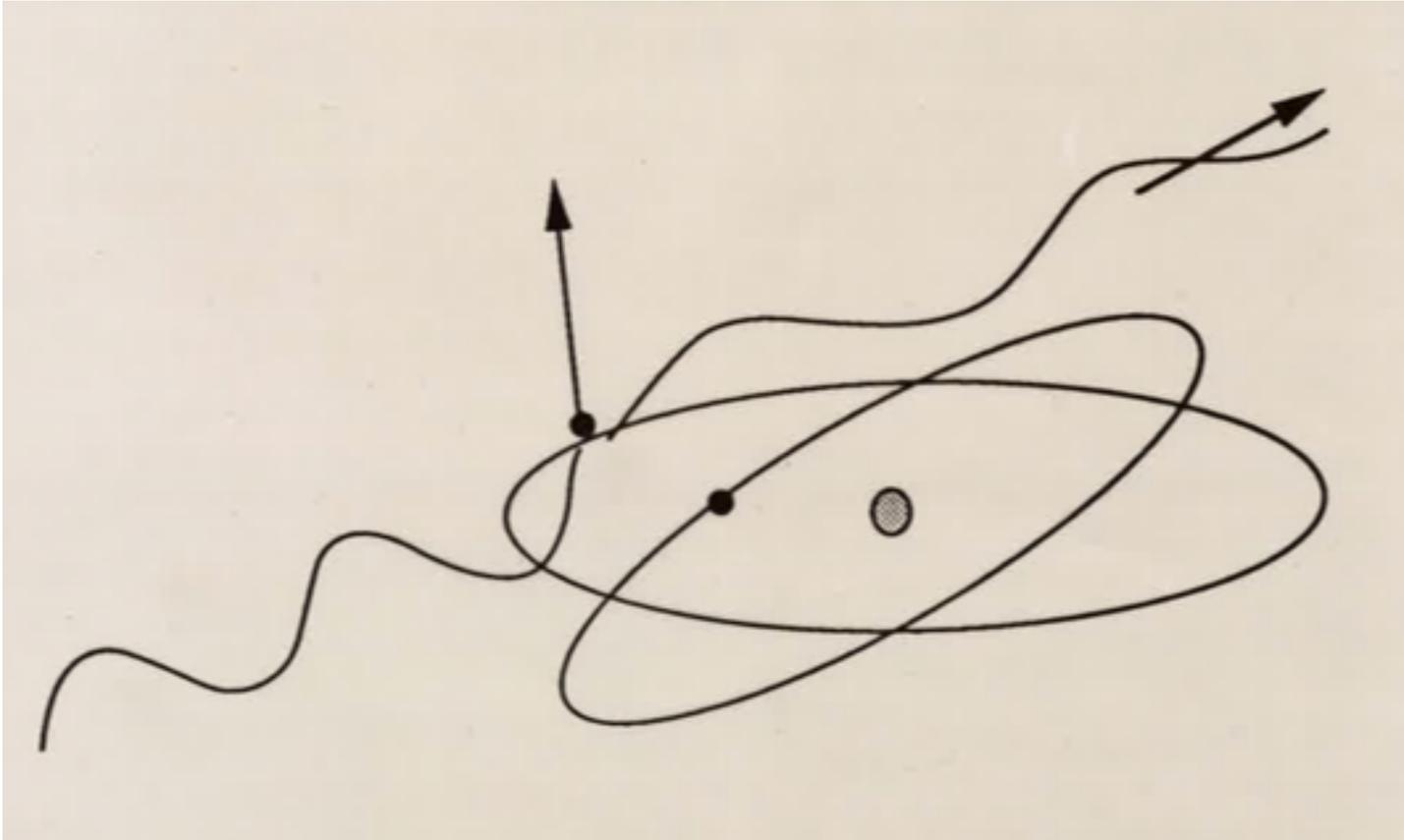

4) Yet another way to ionize: high DC fields

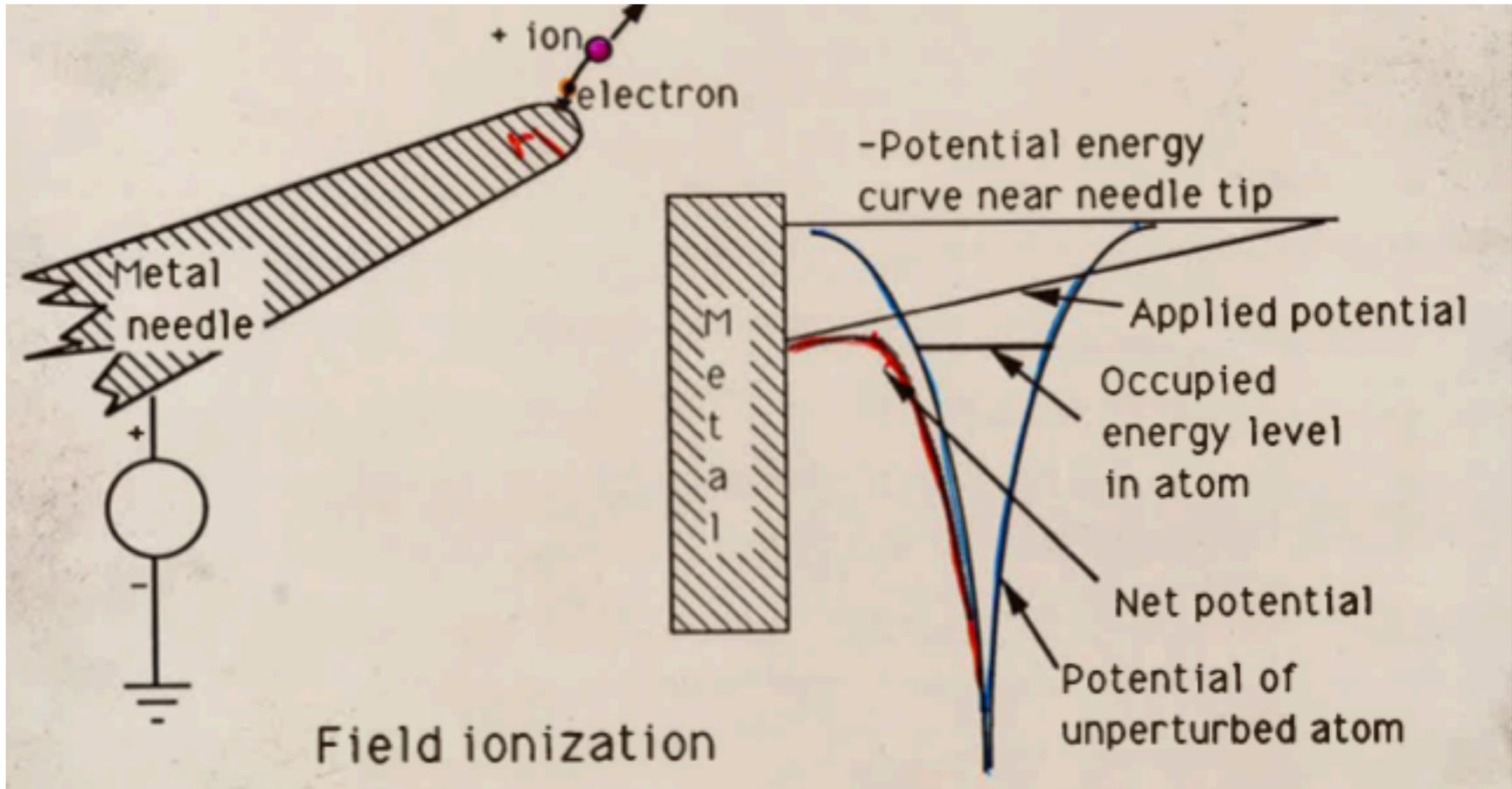

The next step:
from one ion and one electron to millions & billions

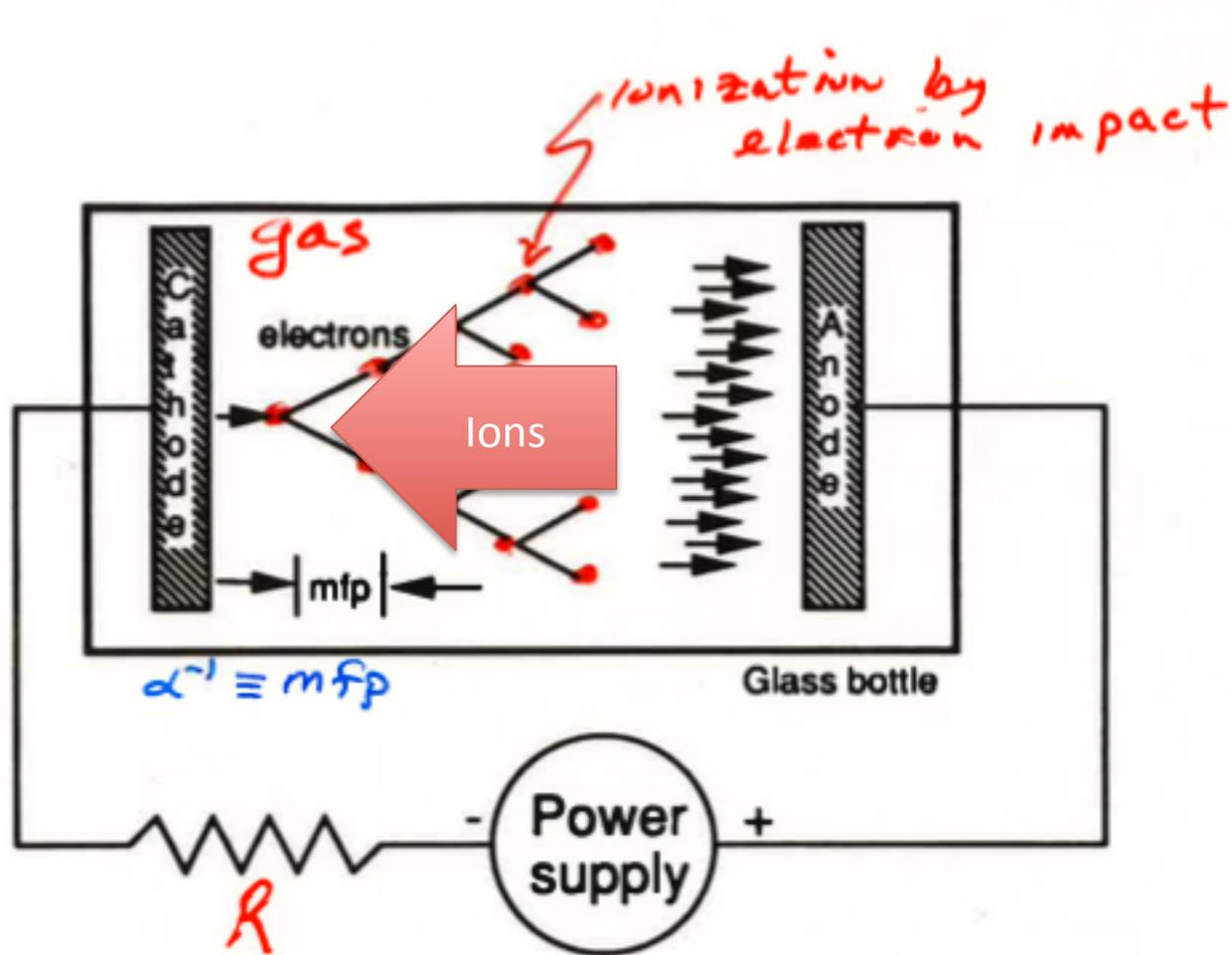

Where the rubber meets the road: boundary conditions

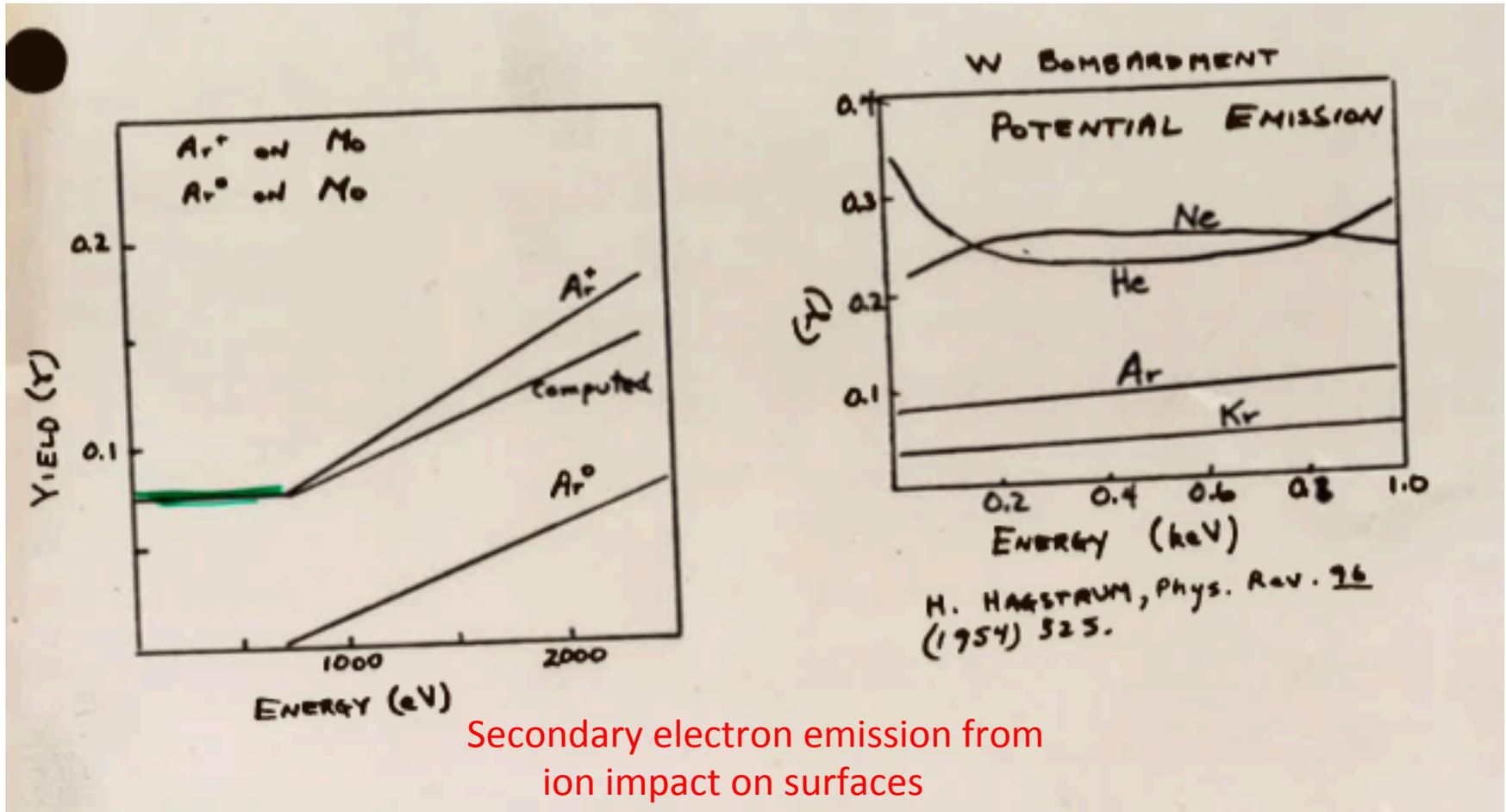

- How many ions must hit the cathode to sustain or build up the ionization?
- How LONG must the glass pipe be?
- What are the natural units of measure for its length?

Iterate: Paschen breakdown



- | <u>Cathode</u> | <u>Gas</u> | <u>Anode</u> |
|----------------------------------|--|--|
| 1) 1 e ⁻ starts | (e ^{αd} -1) ions produced | (e ^{αd}) e ⁻ hit |
| 2) (e ^{αd} -1) ions hit | γ(e ^{αd} -1) ² ions produced | γ(e ^{αd} -1) ² (e ^{αd}) e ⁻ hit |
| 3) | | |

Look for a singularity: Gain > loss

- 1) Which gas has a lower minimum V_B, O₂ or He?
- 2) Does the shape ever change?

If you are lucky, the answers are not what you expect.

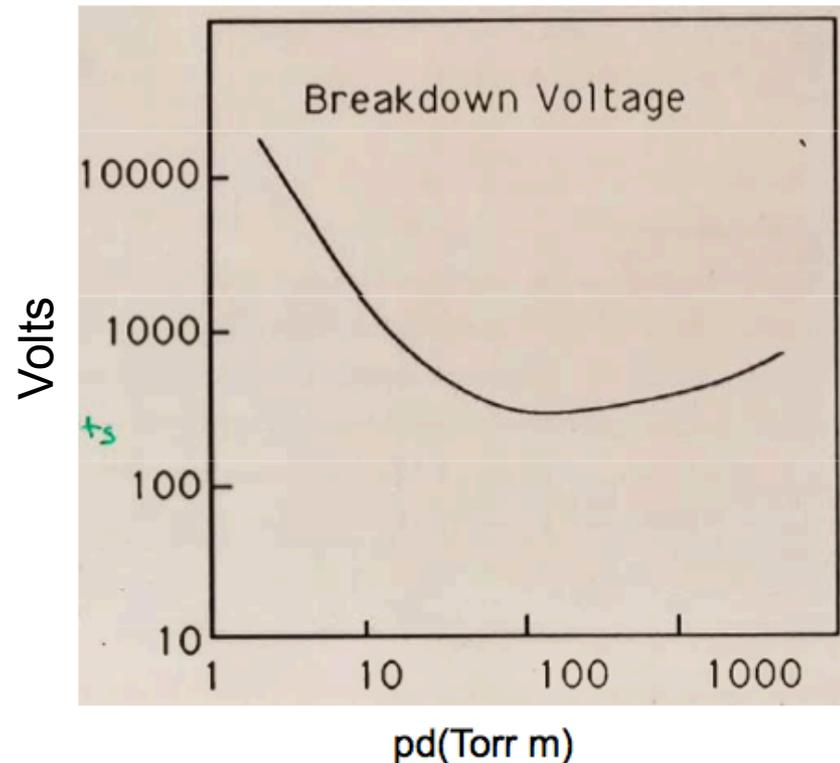

Simple geometry, complex behavior, lots of money

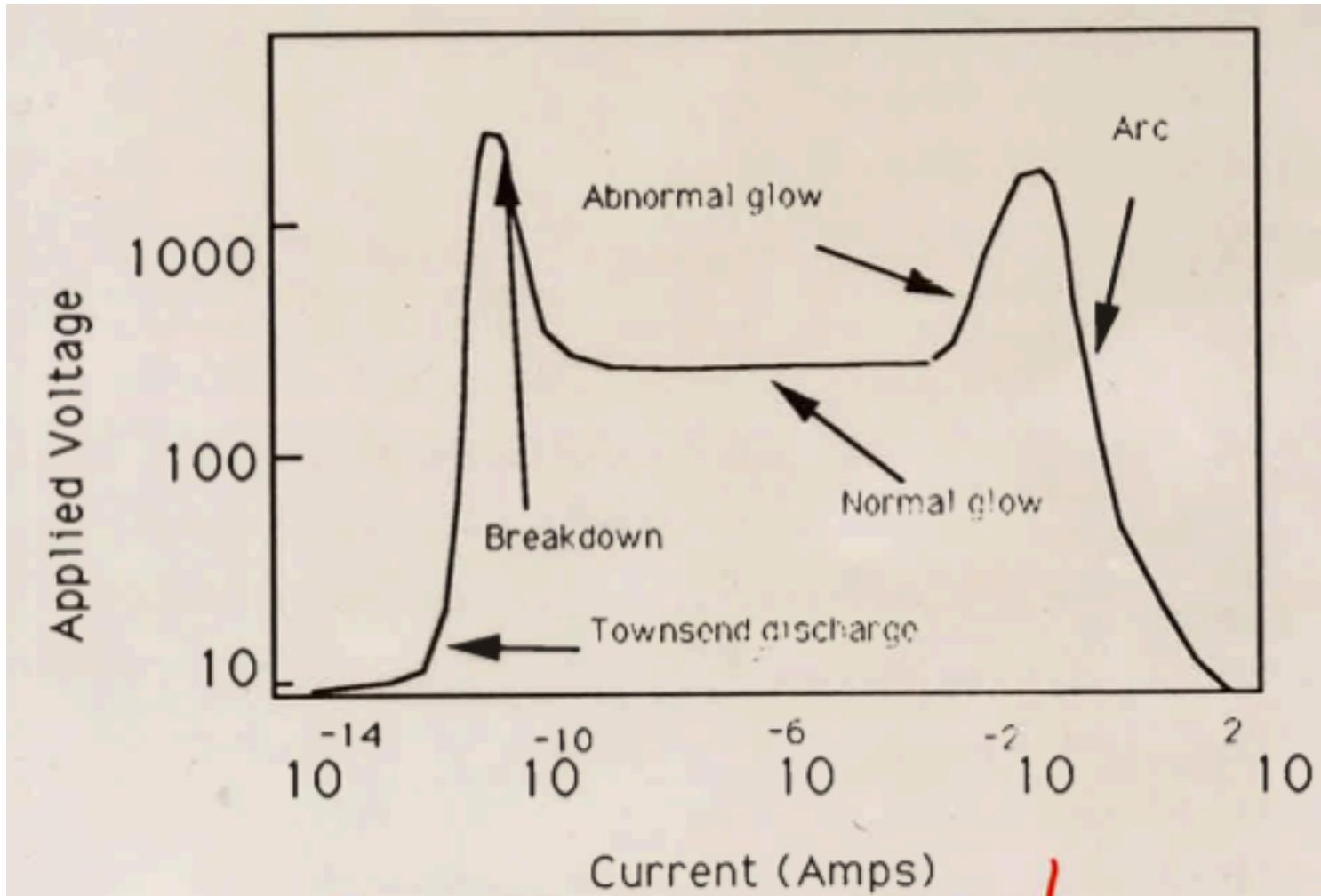

Irving Langmuir

Irving Langmuir was born on 31 January 1881 in Brooklyn, New York. His father was employed by an insurance company and that work took the family to Paris, Philadelphia and New York. After graduating from a technical high school, Langmuir



earned his BS in metallurgical engineering from Columbia School of Mines in 1903. He then went on to Germany, where he earned his PhD from the University of Gottingen in 1906. Afterward he spent three years teaching at Stevens Institute of Technology in New Jersey, where he was often frustrated both by his limited salary and by the fact that teaching demands kept him from research. Dr. Langmuir was happier after he moved to the General Electric Research Laboratory, where he worked from 1909 until his retirement in 1950. Langmuir combined physics, chemistry and engineering in a fruitful way. Throughout the course of his career, his work showed itself to have both theoretical and practical value. Langmuir is considered a pioneer in the fields of plasma physics, chemistry, electronics, and engineering.

Pattern of light emission from a glow discharge

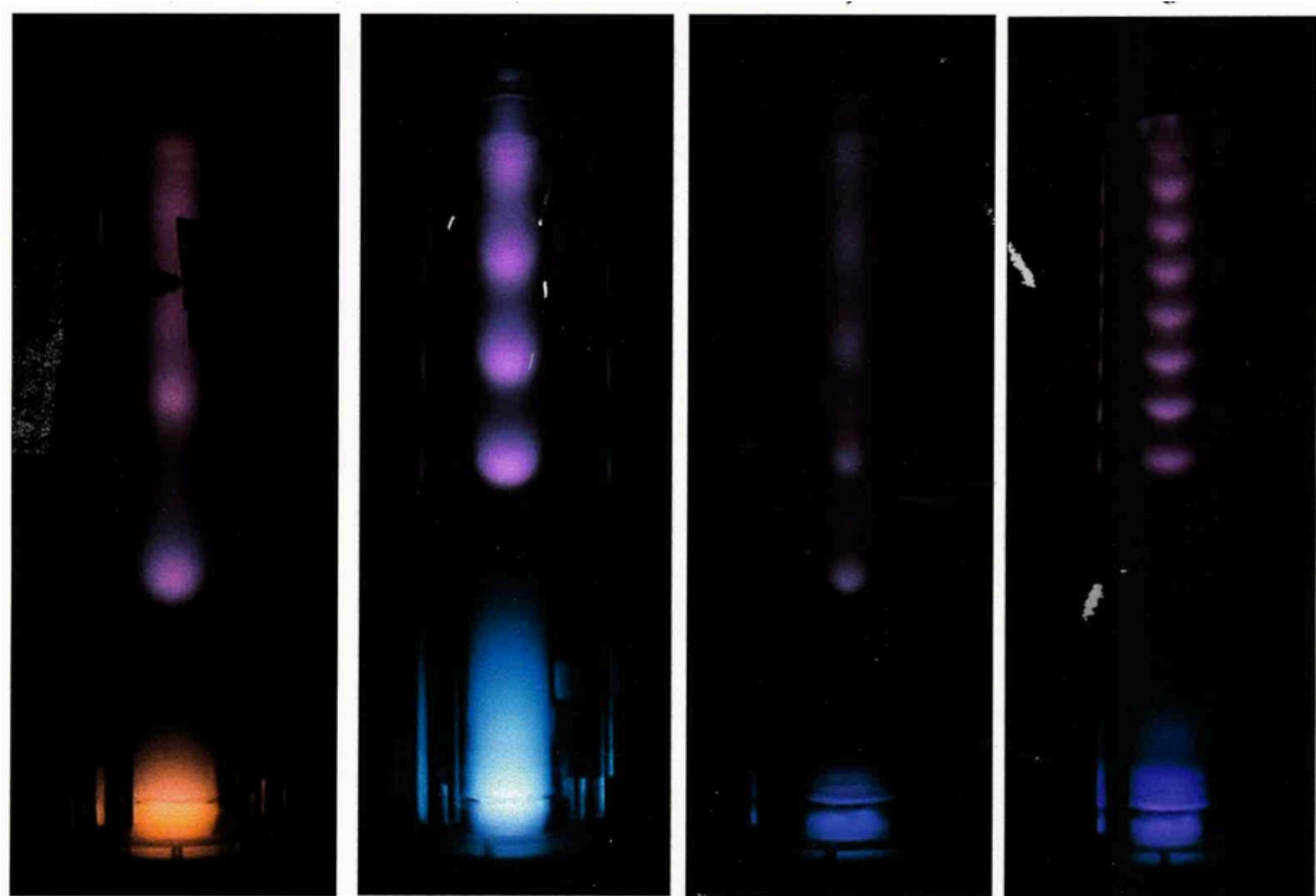

Why the pattern?

Why the multitude of patterns?

Why the different colors?

Continuity?

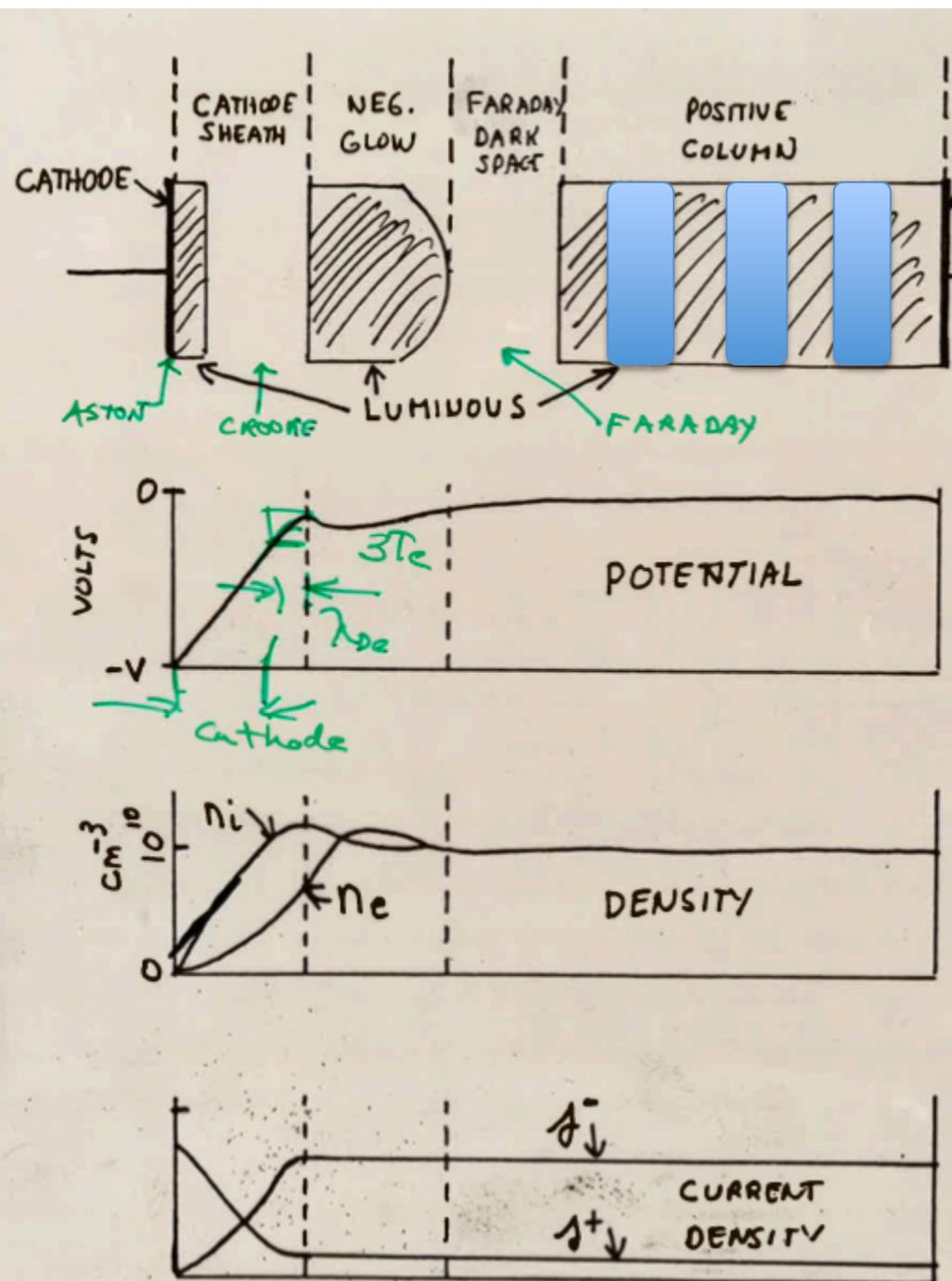

What to look for with plasma diagnostics

- Ion species
- Particle(s) energies, temperatures, densities, flows
- Neutral species
- Waves: propagating, decaying, amplifying
- Modes: macroscopic, microscopic
- Turbulence
- Transport: particles and energy
- Fusion events
- Radiation
- Potentials

Langmuir probe(s)

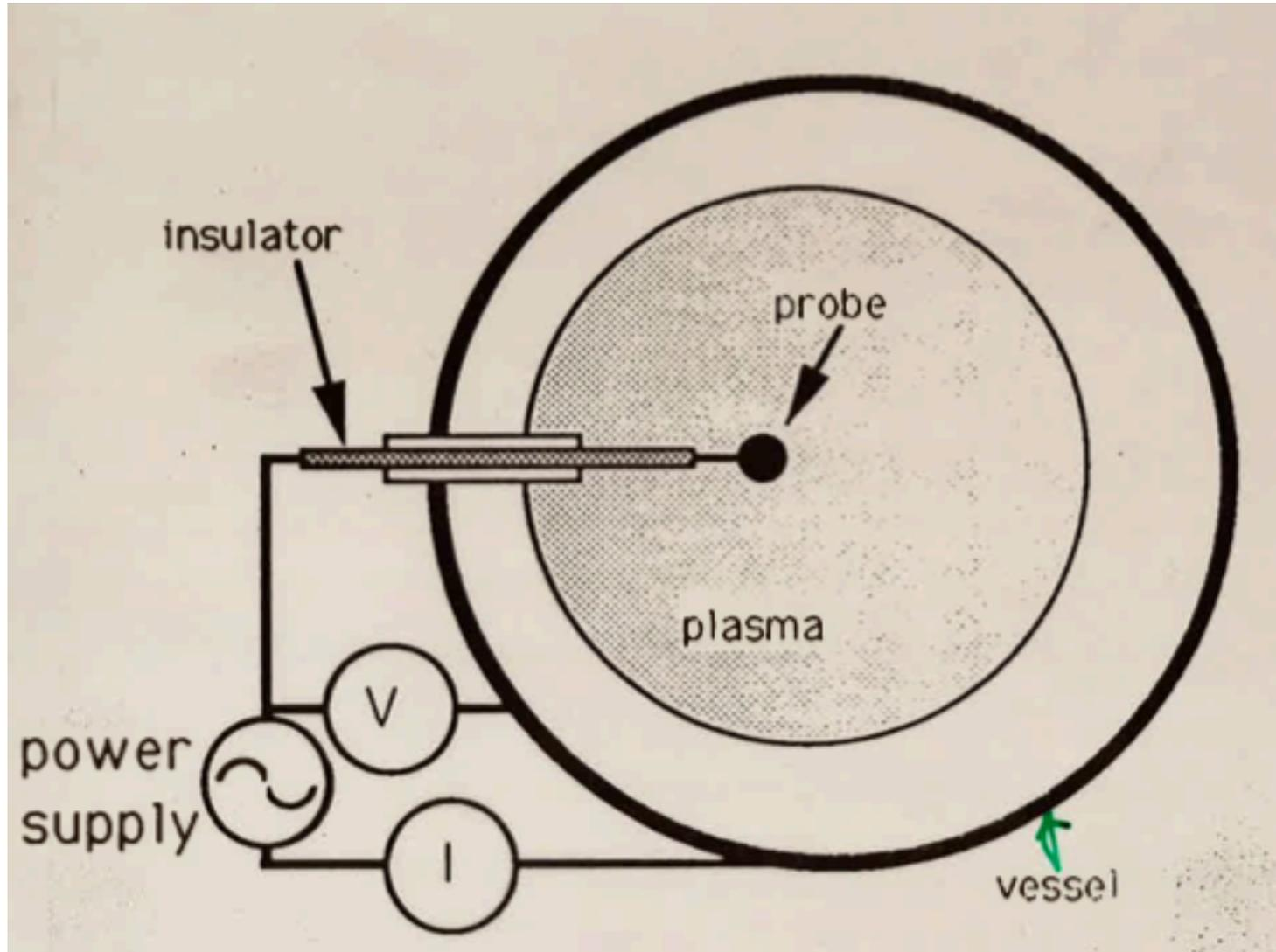

Langmuir characteristic: n_e, T_e

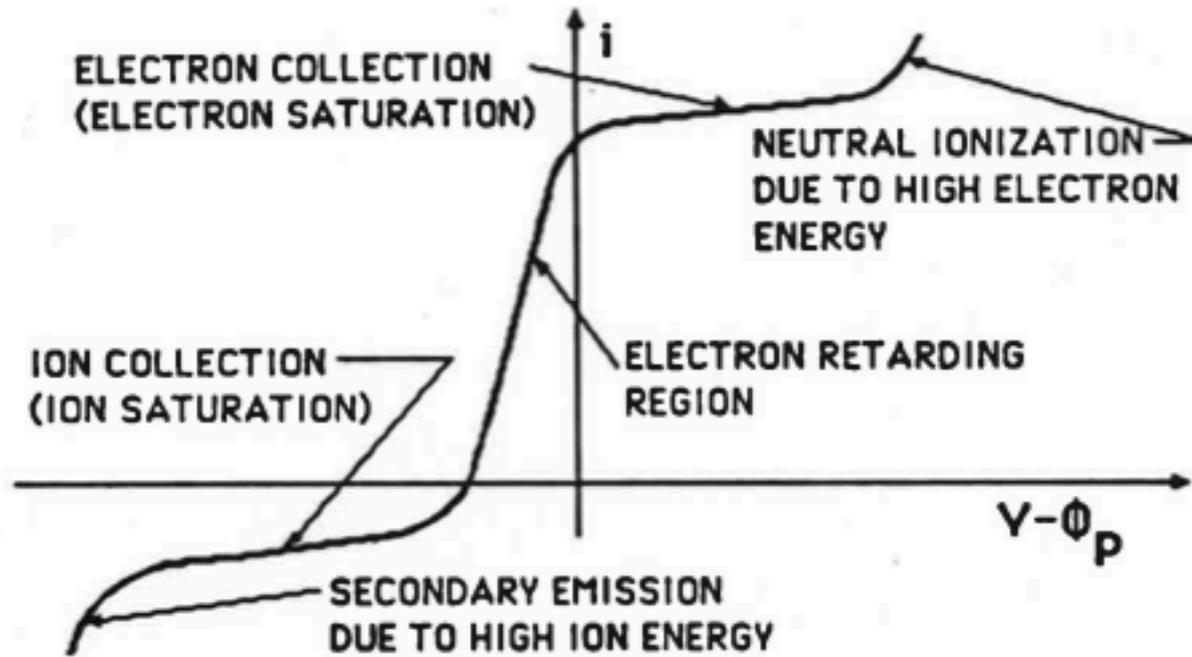

Figure 2: Typical probe characteristic
(not to scale)

V = probe voltage

i = probe current

Φ_p = potential of plasma with respect to wall

$$I = n q v A$$

Langmuir data
for n , T , ϕ

What are the
limits for
Langmuir
probes?

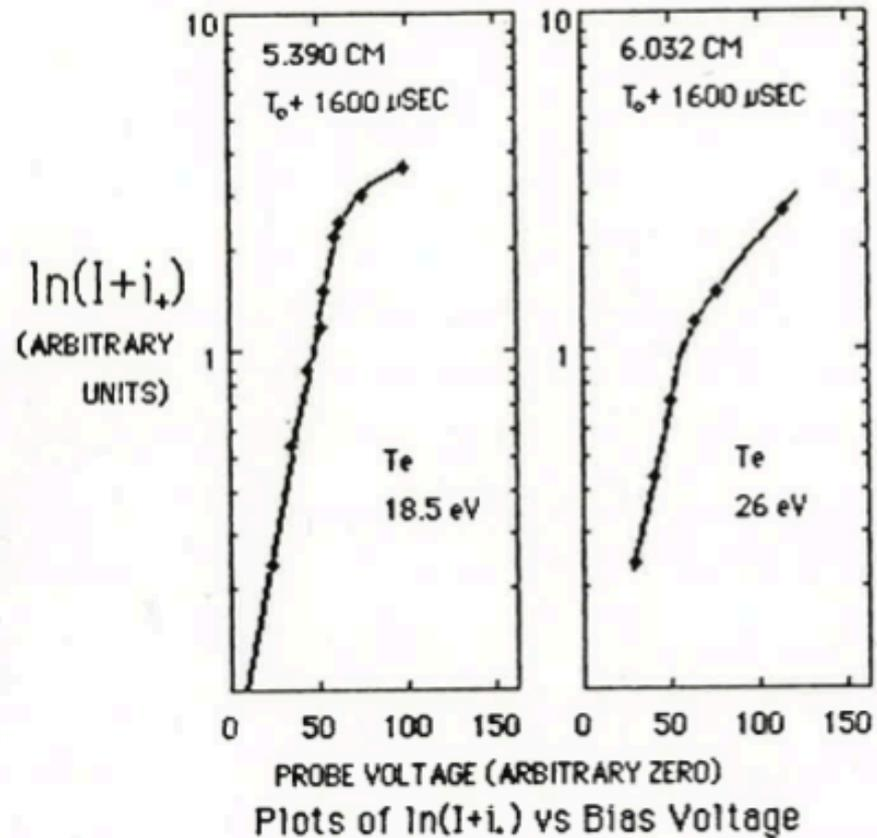
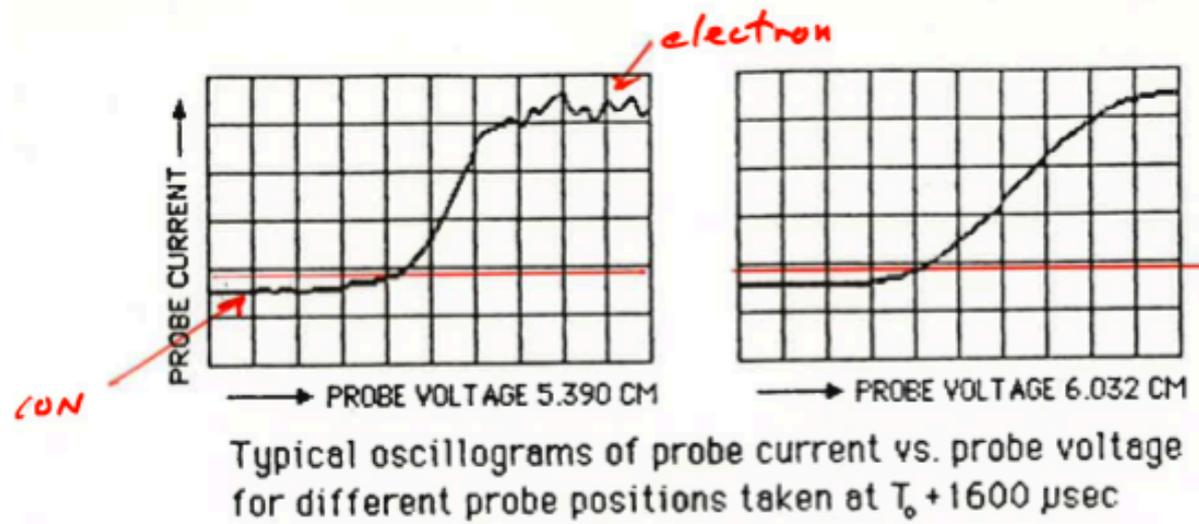

Another type of probe: capacitive

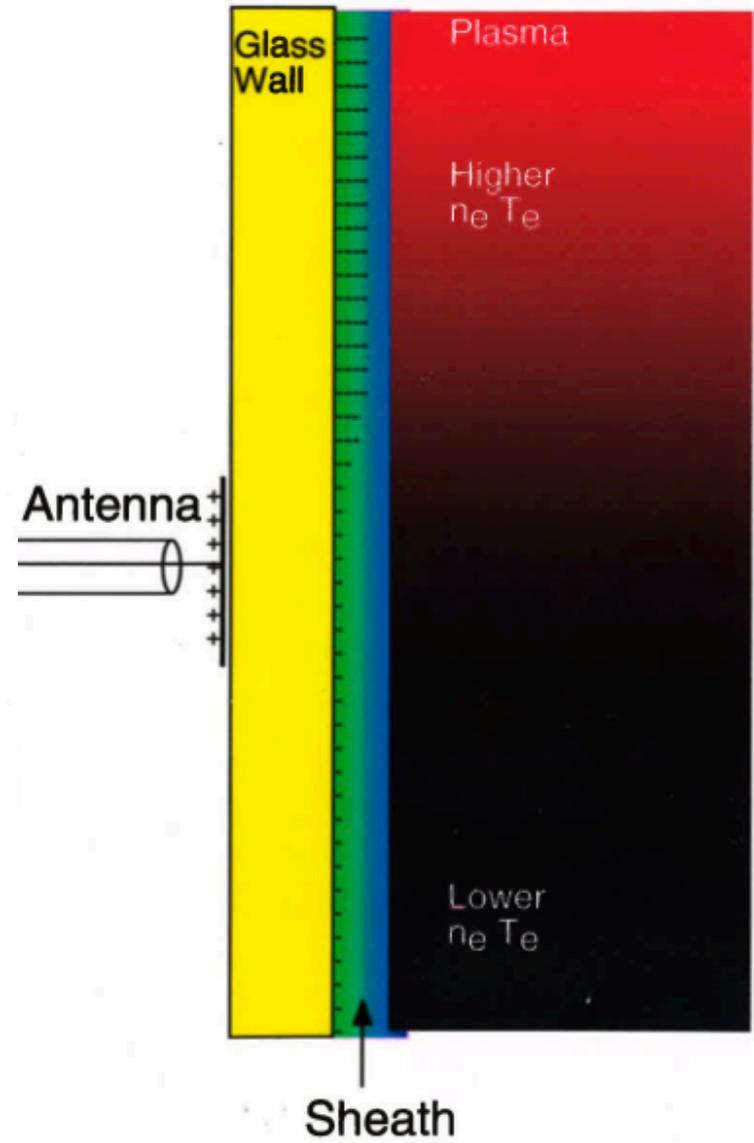
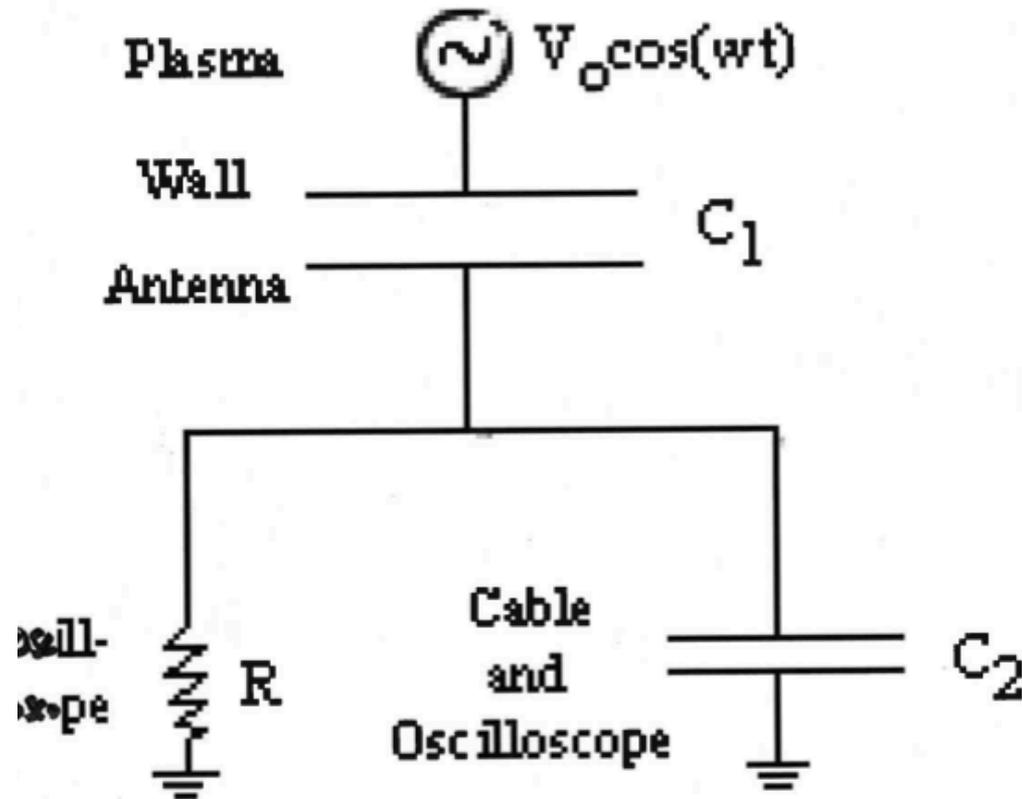

What capacitive probe data might look like: scanning voltage



Signal

FFT

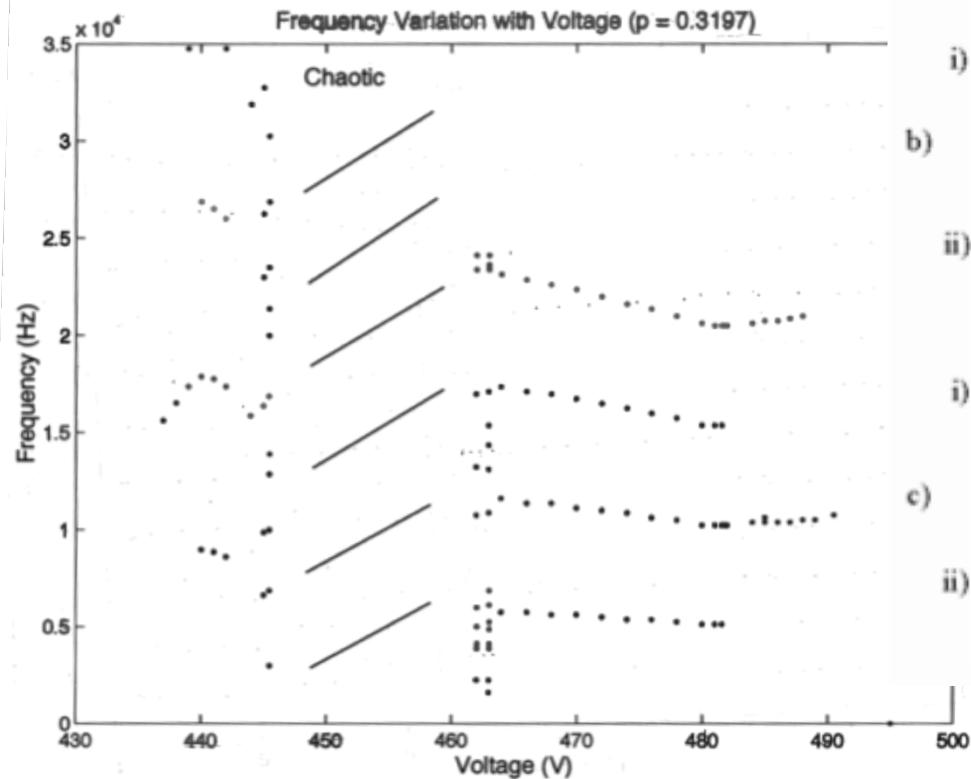
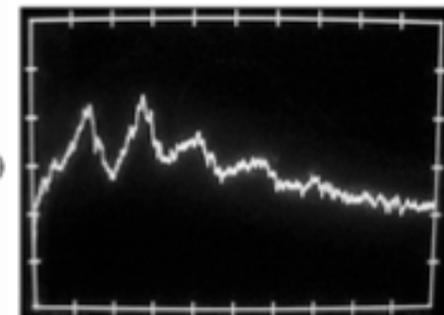
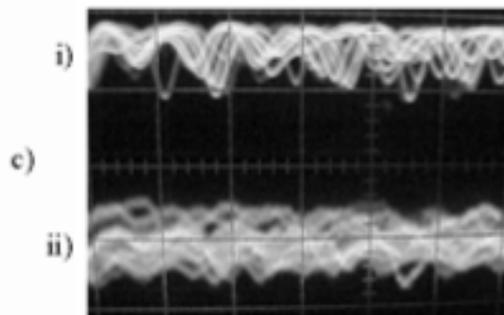
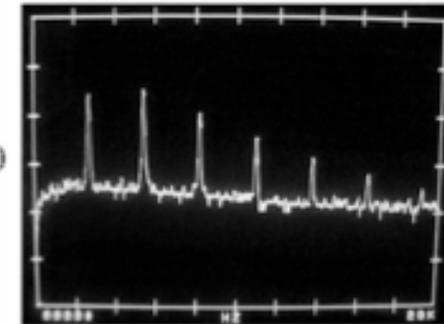
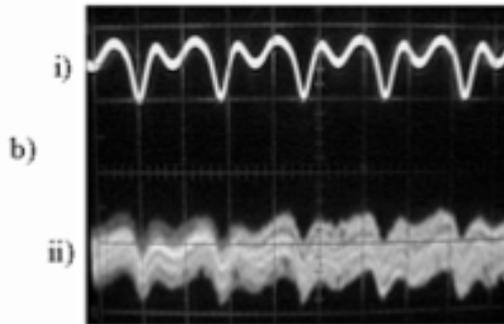
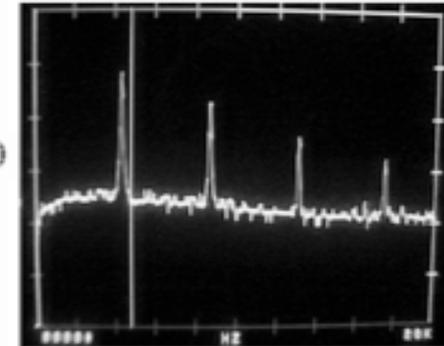
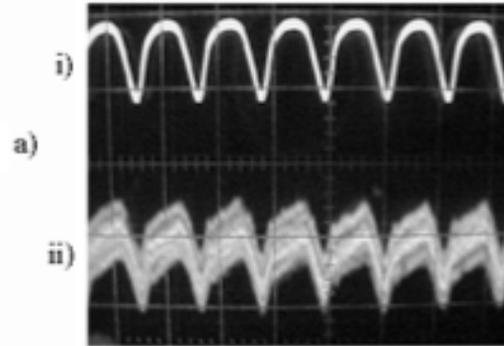

WHY?

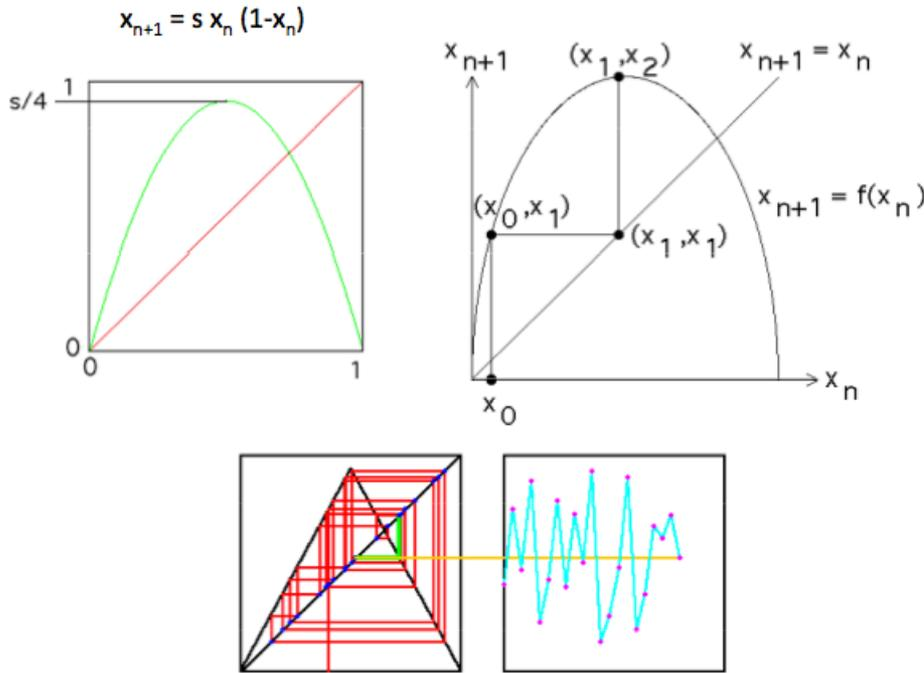

review article

Simple mathematical models with very complicated dynamics

Robert M. May*

First-order difference equations arise in many contexts in the biological, economic and social sciences. Such equations, even though simple and deterministic, can exhibit a surprising array of dynamical behaviour, from stable points, to a bifurcating hierarchy of stable cycles, to apparently random situations. There are consequently many fascinating problems, some concerned with delicate mathematical aspects of the fine structure of the trajectories, and some concerned with the practical implications and applications. This is an interpretive review of them.

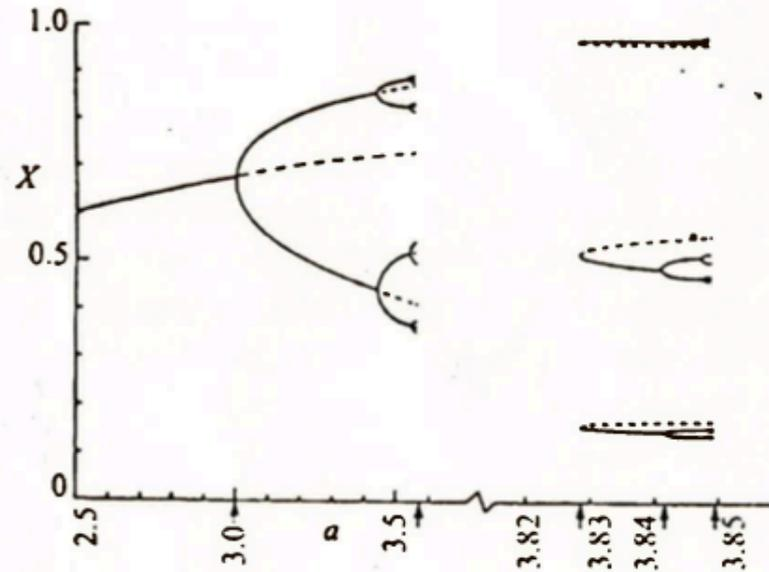
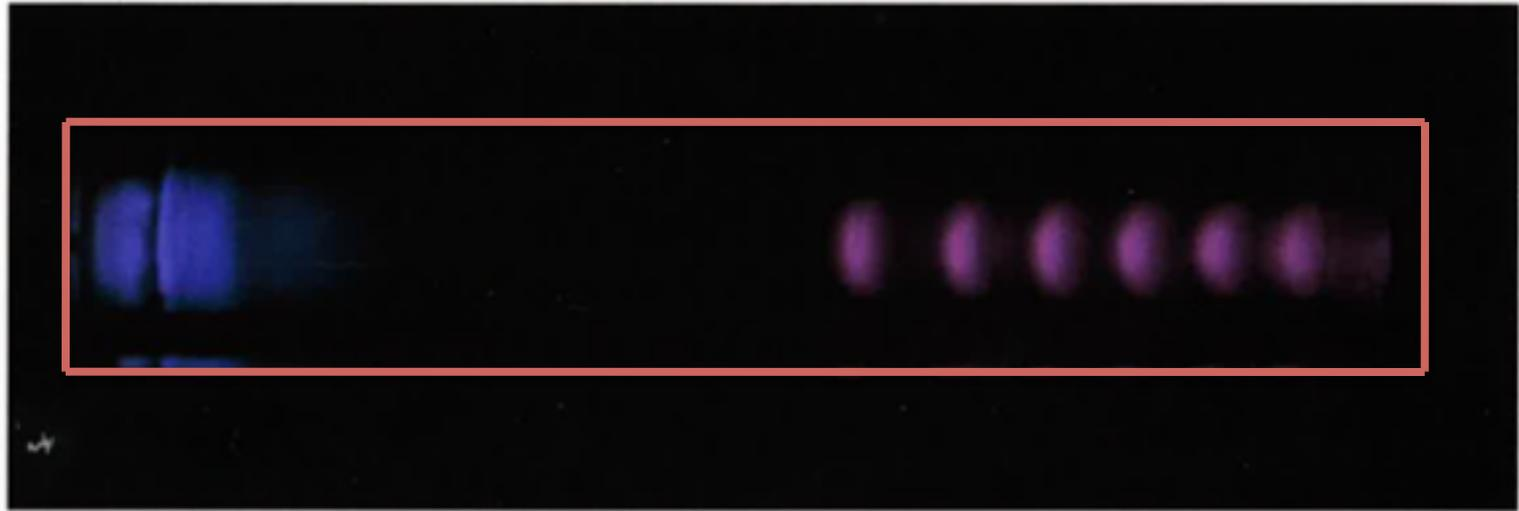

Fig. 4 This figure illustrates some of the stable (—) and unstable (---) fixed points of various periods that can arise by bifurcation processes in equation (1) in general, and equation (3) in particular. To the left, the basic stable fixed point becomes unstable and gives rise by a succession of pitchfork bifurcations to stable harmonics of period 2^n ; none of these cycles is stable beyond $a = 3.5700$. To the right, the two period 3 cycles appear by tangent bifurcation: one is initially unstable; the other is initially stable, but becomes unstable and gives way to stable harmonics of period 3×2^n , which have a point of accumulation at $a = 3.8495$. Note the change in scale on the a axis, needed to put both examples on the same figure. There

Where? In seemingly stable discharges



New topic: Using microwaves to measure plasma behavior

- Characteristic frequencies in ITER
 - Ion cyclotron: 100 MHz
 - Electron cyclotron: 300 GHz
 - Electron plasma: 100 GHz
 - Ion collision rate: 10 Hz
 - Fusion rate: 0.1 Hz

EM waves in a cold, collisionless, unmagnetized plasma

$$k^2 c^2 / \omega^2 = n^2 = 1 - \omega_{pe}^2 / \omega^2$$

Phase velocity = ω/k

Black body radiation

$$\lambda_{\text{peak}} T = .288 \text{ (K cm)}$$

$$\text{Power} = \epsilon A \sigma T^4$$

$$\sim 5 (T(\text{K})/1000)^4 \text{ W/cm}^2$$

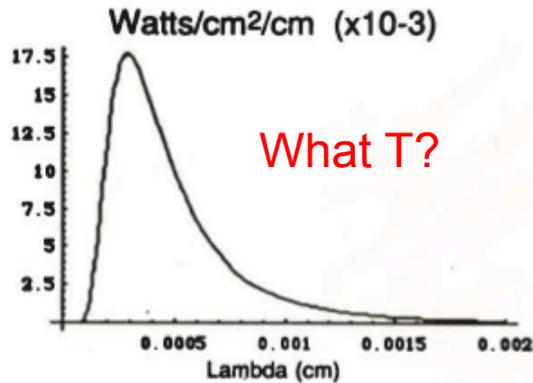

A blackbody emission spectrum

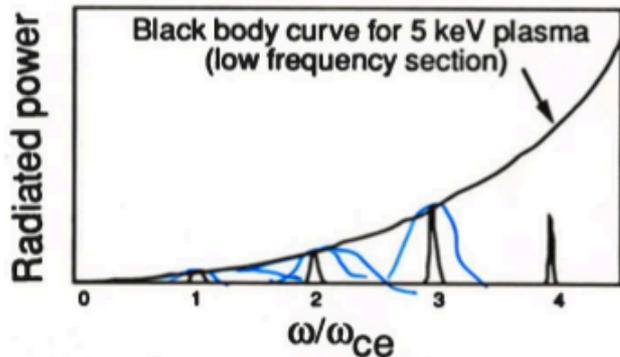

Some cyclotron harmonics emitted by a magnetized plasma.

1. Electron temperature and temperature profiles

Emission $\sim T$ (for some harmonics)

$$\omega \sim B \sim 1/R$$

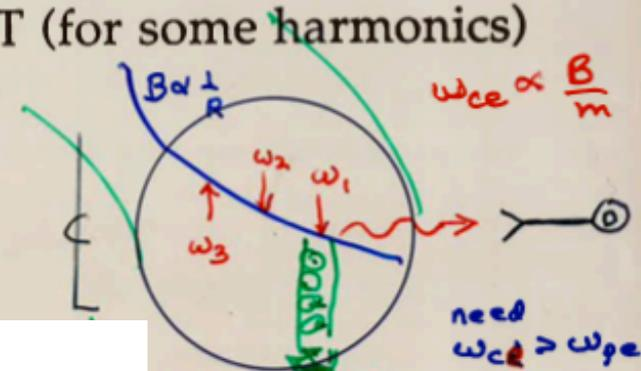

Density measurements.

A. Reflectometry



B. Interferometry

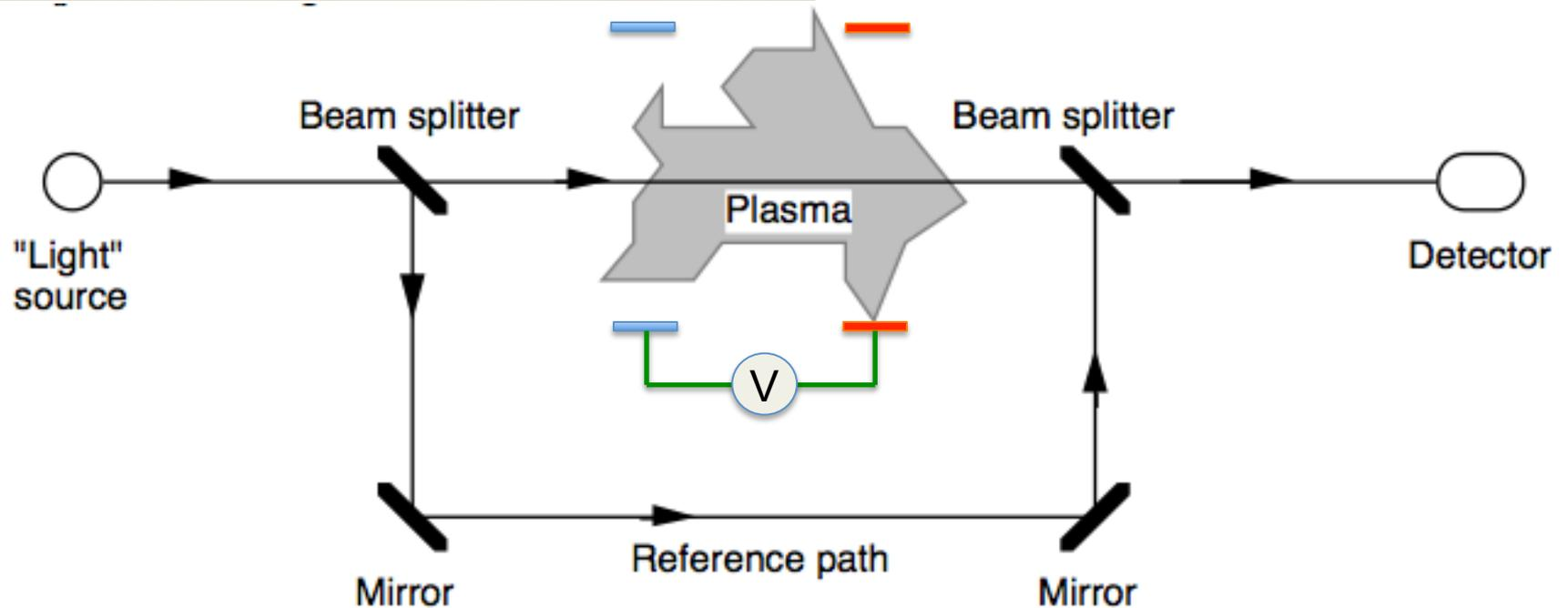

Hare & Plasek

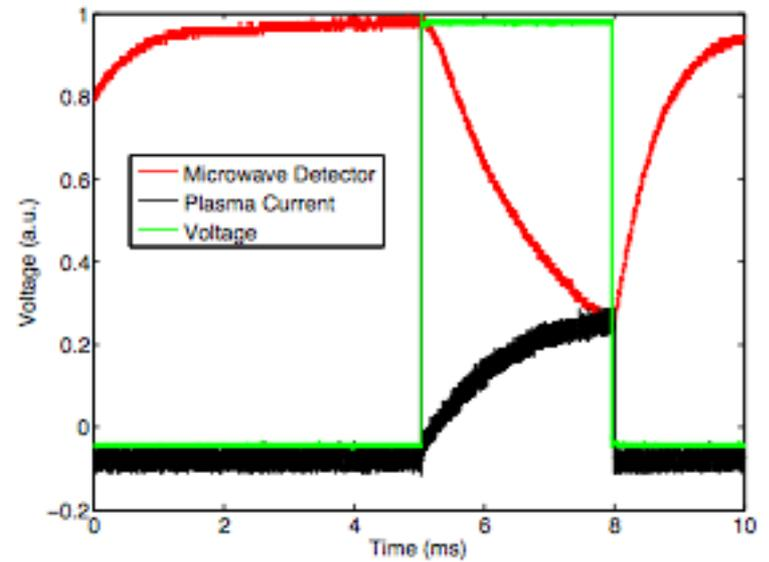

Spectroscopy: passive

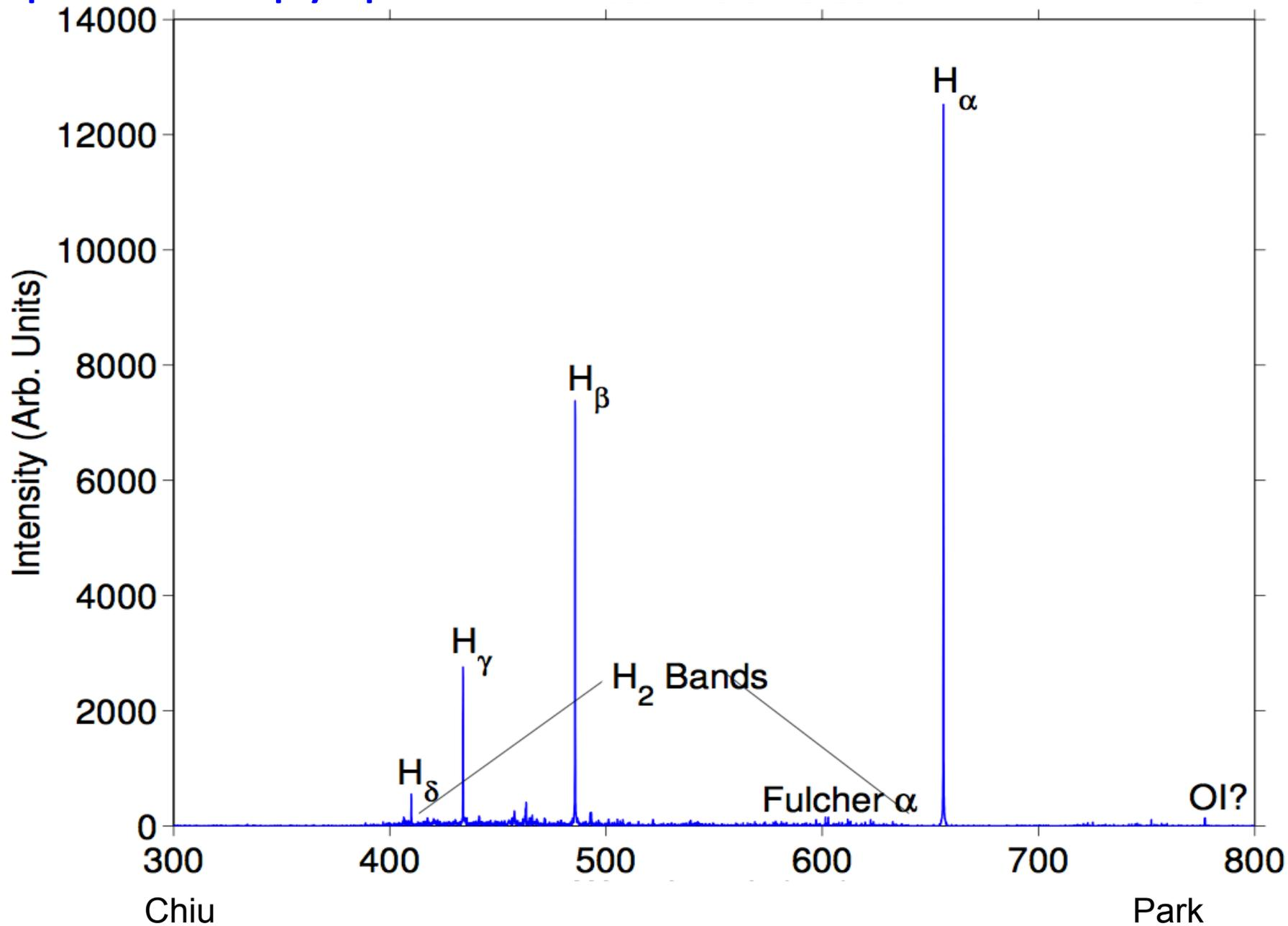

Spectroscopy: Active (LIF)

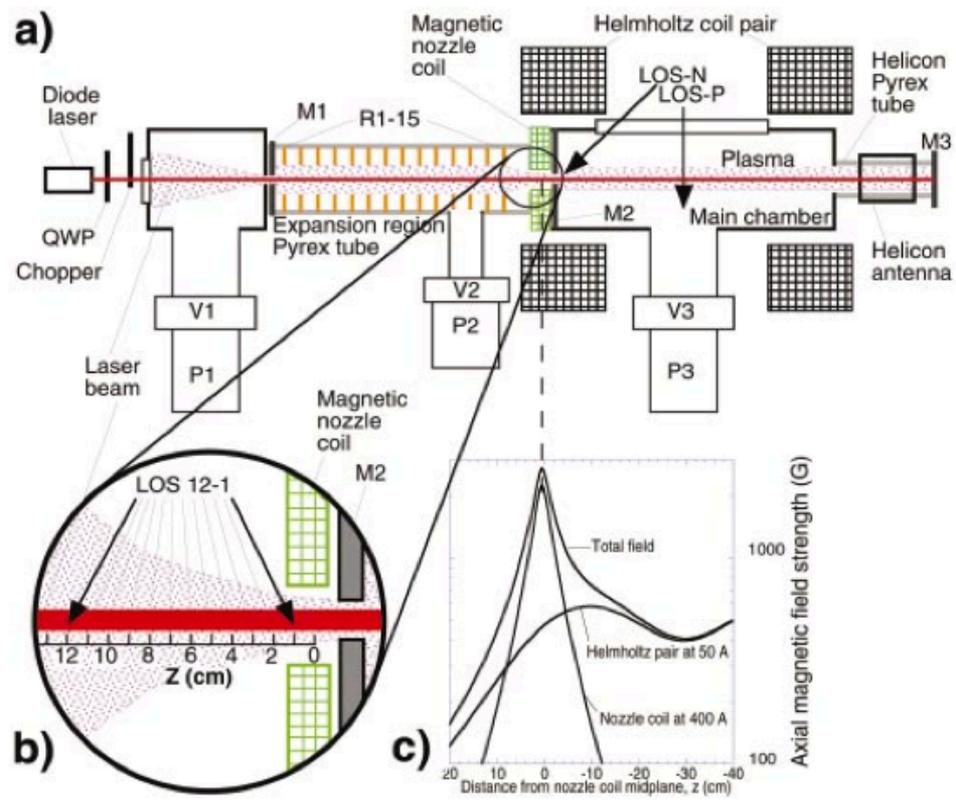
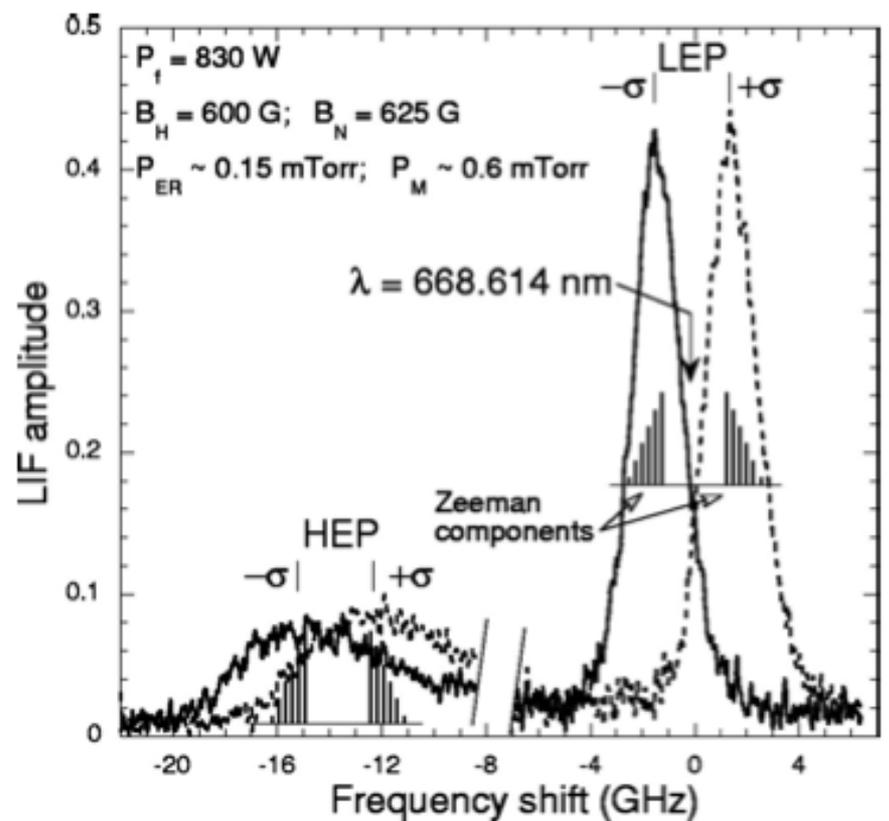

RMF_0 -formed collisionless high- β plasmas: Yesterday, today and tomorrow

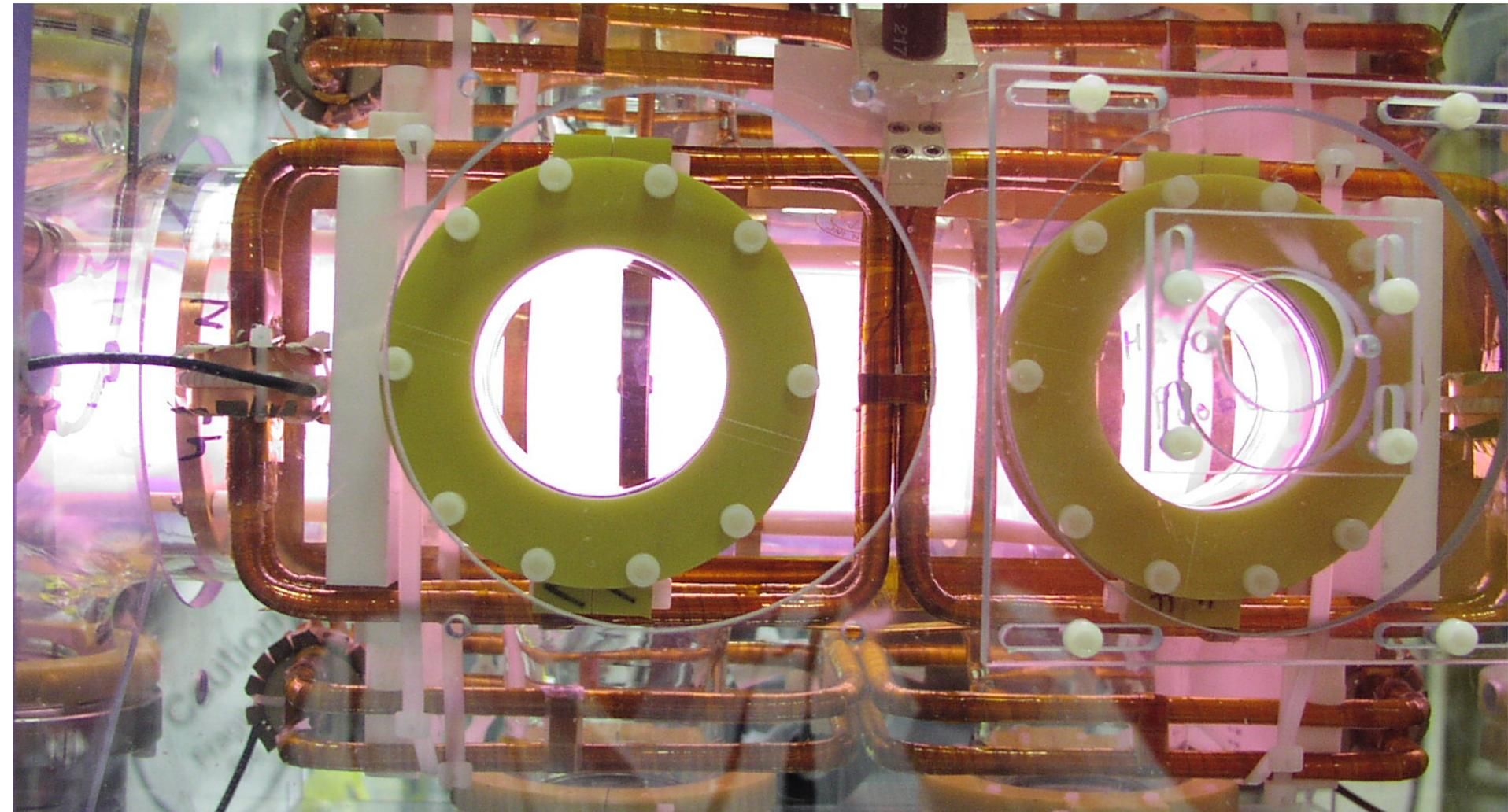

- Comparison between FRC and tokamak
- Particle orbits in the FRC
- Theoretical predictions for RMF₀-heated FRC
- RMF₀/FRC experimental results at PPPL
- The path to a van-sized reactor: point design
 - Lower neutron production
 - Prompt loss of charged fusion products (driven)
 - Steady state
 - 5 MW_{Thermal}

MFE: The Tokamak and the FRC

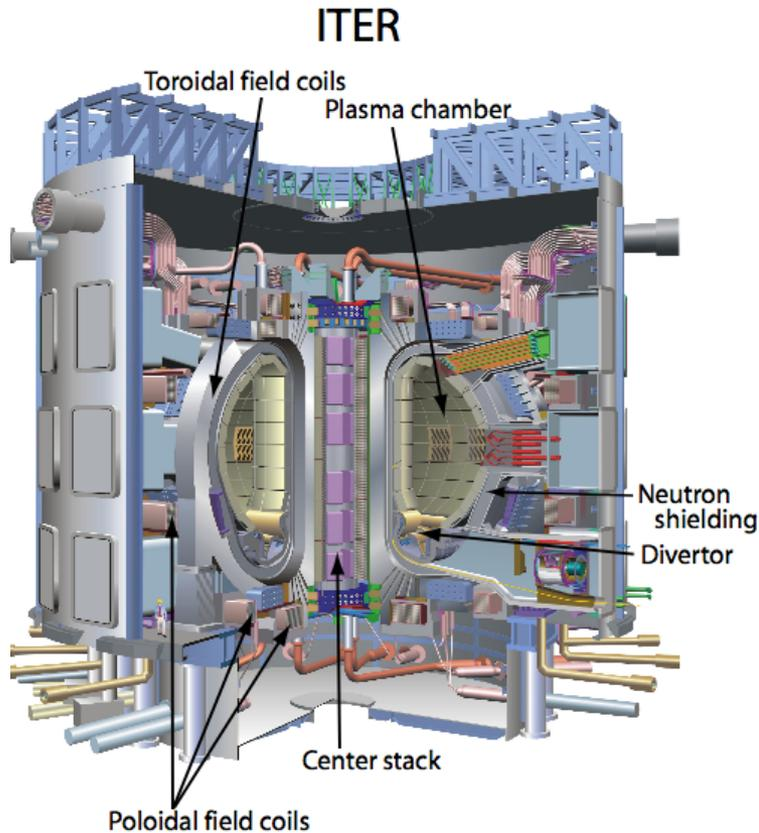

- Tokamaks- the mainline magnetic confinement program - have been extraordinarily successful in producing hot dense fusion plasmas.
- Most of the remaining steps necessary to make tokamaks “practical” are *technological and expensive*.
- Experiments show that tokamaks only “work” when they are *big*.

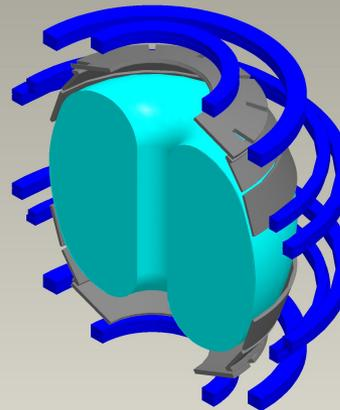
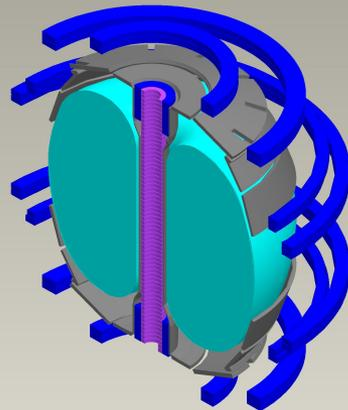
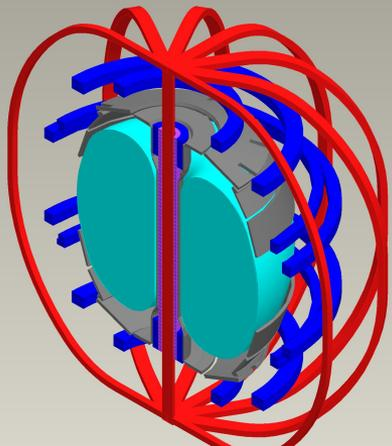

FRC

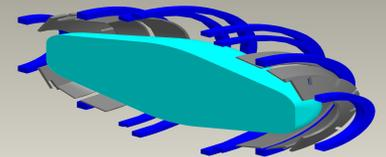

The Tokamak and the (generic) FRC

Tokamak

FRC

$\langle \beta \rangle \ll 1$	←	$\langle \beta \rangle \sim 1$
Toroidal magnets	←	Linear solenoid
Strong B_t at coils	←	$B_t = 0$
Strong B on axis	←	$B = 0$ on minor axis
Current to B		Current ⊥ to B
Material in middle	←	No material or hole in middle
Field lines cover surface	←	Field lines stay lines
Bigger	←	Smaller
Burns predominantly D-T	←	Could burn <i>cleaner</i> fuel
Extensive database	←	Weak database
MHD stability, understood	←	Kinetic stability, unknown

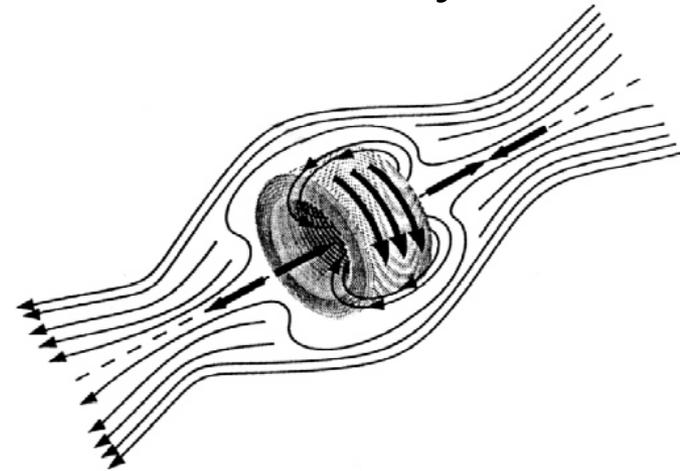
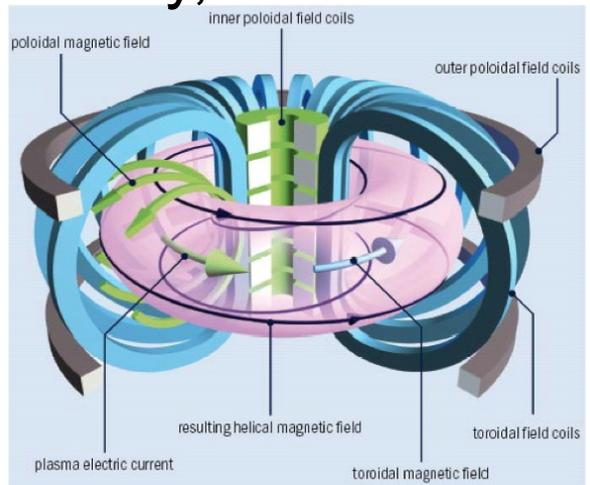

The quickest path? The size-field plane

Tokamak

Comparing MFE reactor concepts

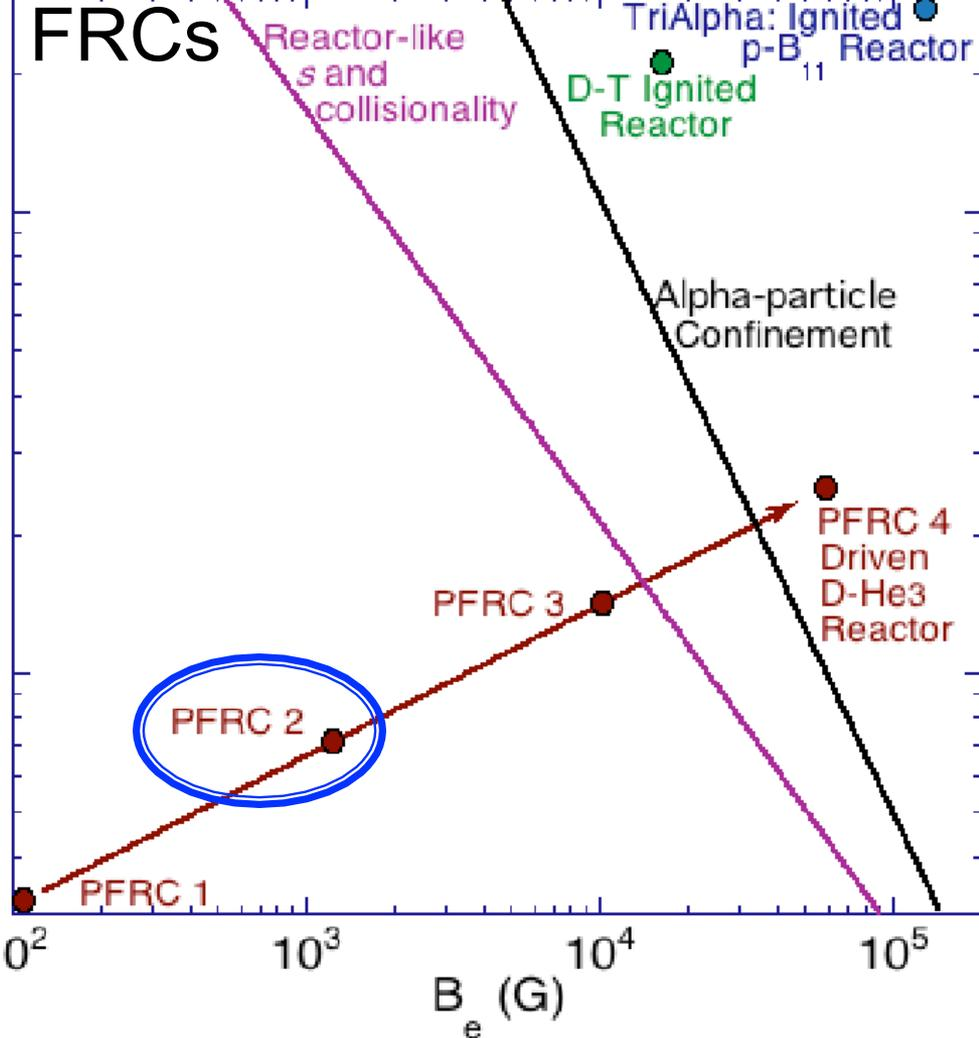

Choices

1. Fuel
2. Beta
3. Configuration
4. Heating method

Nature

1. τ_E
2. Size
3. Stability
4. Fusion power

$$\text{Fusion power} = n_1 n_2 \langle \sigma v \rangle V E_f$$

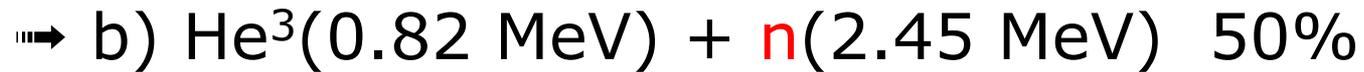

Aneutronic



Charged fusion products

vs neutrons

- Direct energy conversion/extraction
- Plasma heating
- No neutron activation of structure
- Less shielding
- No tritium breeding
- Less materials development/testing

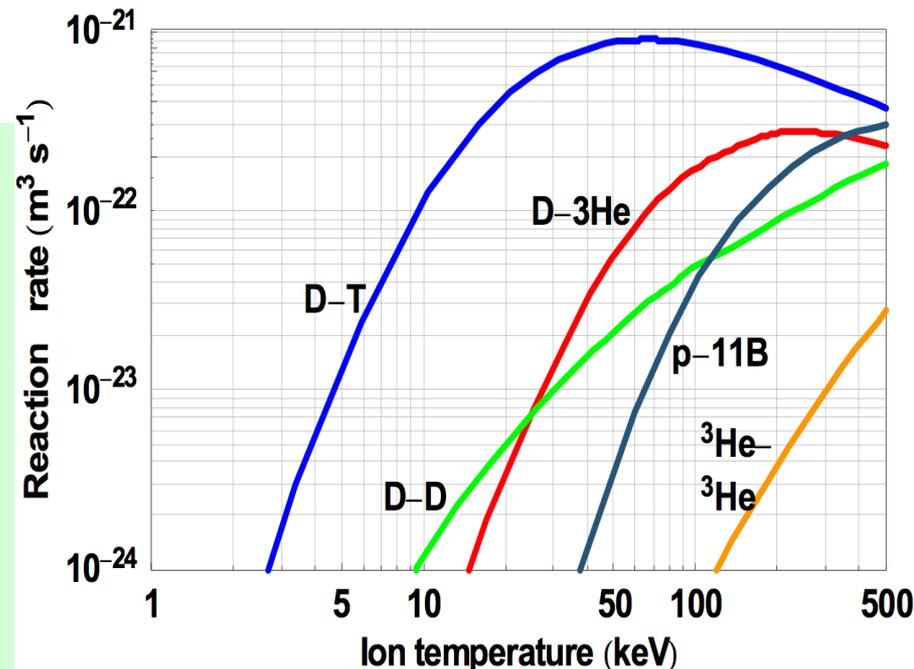

Reduce neutron shielding requirements

Reduction in shielding-thickness requirement compared to ITER

- Lower power density
- Fewer neutrons/unit power
- Lower energy neutrons
- More power/fusion
- Greater surface-to-volume ratio
- Passive FCs, vs powered TF coils - no electrical insulation
- Shorter FC lifetime permitted because of accessibility
- Higher heat load permitted for Hi-T SC
- Outboard shielding only
- Higher duty factor

Net effect $> 10^5$!!
20 cm of shielding is sufficient

Fuel: Chose D-³He (mine the moon)

Power density @ $n_e = 8 \times 10^{20} \text{ m}^{-3}$, $10^{-22} \text{ m}^3/\text{s}$,

		$T_i(\text{keV})$	$B_o(\text{T})$	$\langle \beta \rangle$
$P_{\text{D-T}}$	$= 45 \text{ MW/m}^3$ (9 MW/m ³ in plasma)	10	10	0.06
$P_{\text{D-He3}}$	$= 20 \text{ MW/m}^3$ (at 50/50)	70	8	0.6
$P_{\text{p-B11}}$	$= 2.5 \text{ MW/m}^3$	140	10	0.6
$P_{\text{D-D}}$	$= 20 \text{ MW/m}^3$ (at 50/50)	230	15	0.6

- Need to ameliorate T creation and ash build-up problems.

Reduce D concentration

Encourage **most** fusion products to be **promptly lost** (low B, small R)

J. Dawson: FRCs, p-¹¹B burning

L. Zakharov: tokamaks, liquid lithium walls

D. Barnes: FRCs, DT burning, heat engine

- Don't "waste" pressure on confining *certain* fusion products.
- Promote non-Maxwellian ions to decrease n further
- Earth-sourced ³He can power 100 5-MW power plants for 100 years

Nick Christofilos

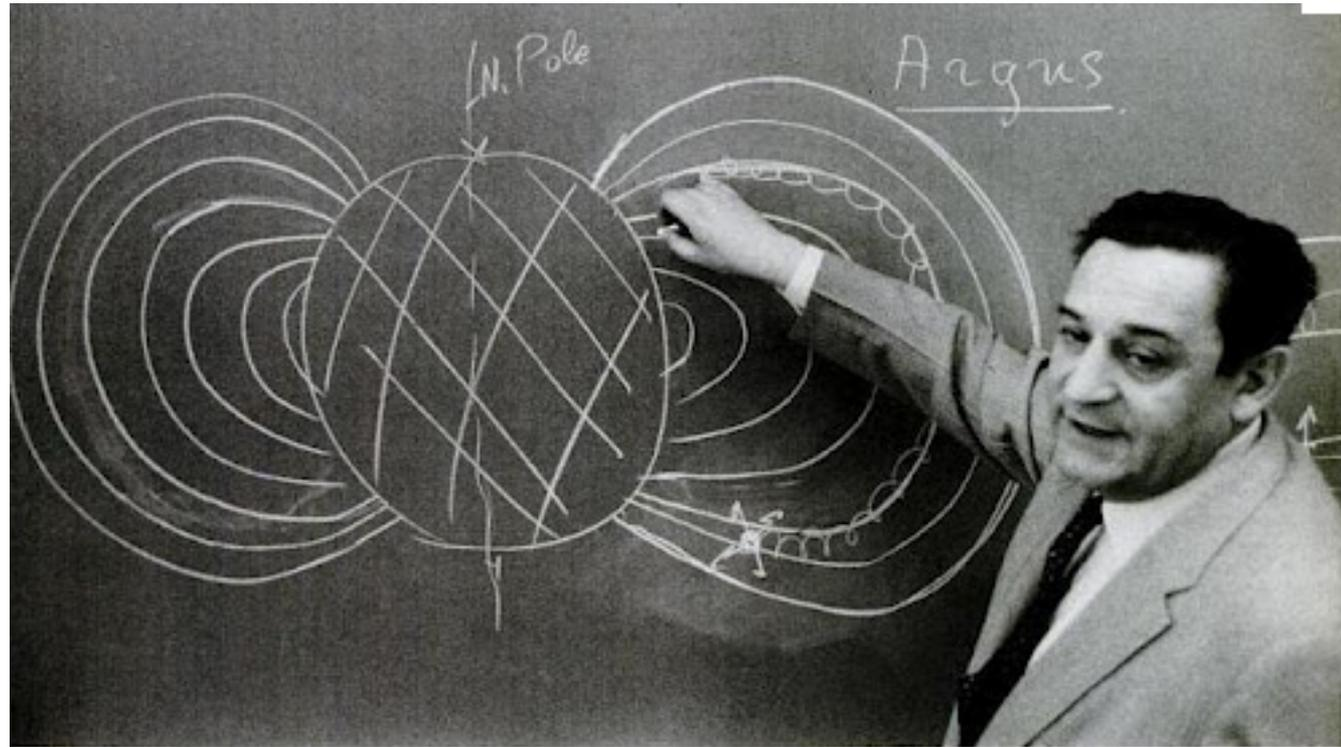

EXPLAINING ARGUS, Christofilos shows how magnetic field encompasses the earth (center). When nuclear bomb is detonated (symbol at lower right) some of

its radiation is trapped and travels along lines of magnetic force to point at opposite end of line. Then it spreads around the earth in a thin shell of electrons.

TRIUMPH IN SPACE FOR A 'CRAZY American

Theory of Boston-born maverick scientist led to sensational Project Argus

J Fusion Energ

DOI 10.1007/s10894-011-9392-5

REVIEW ARTICLE

Greek Fire: Nicholas Christofilos and the Astron Project in America's Early Fusion Program

Elisheva R. Coleman • Samuel A. Cohen •
Michael S. Mahoney

Field-reversed configuration genealogy

- 1958: Christofilos invents ASTRON.
- 1959: Kolb produces 1st θ -pinch FRC.
- 1962: Blevin and Thonemann describe current drive.
- 1963: Wells merges spheromaks.
- 1973: Fleischmann achieves FRC by e^- -beam injection.
- 1979: Rosenbluth *predicts* FRC tilt instability, τ_A .
- 1980s: Jones, Hugrass, *et al.* extensive rotamak (RMF_e) experiments & theory.
- 1988: LANL θ -pinch FRC program ends.
- 1989: Bellan notes open-B energy loss.
- 1992-2004: Hoffman *et al.*, 60 MW RMF_e.
- 1995: Rostoker colliding-beam p-¹¹B reactor research begins.
- 2001: RMF_o *discovered*. Improved heating, confinement & stability predicted.
- 2005: RMF_o experiments begin at PPPL. $t > 10^3 \tau_A$

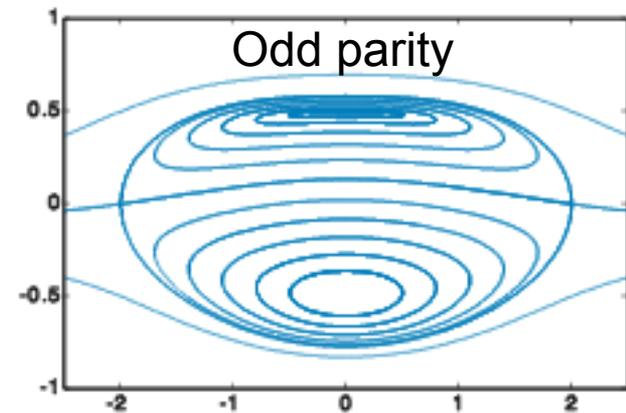
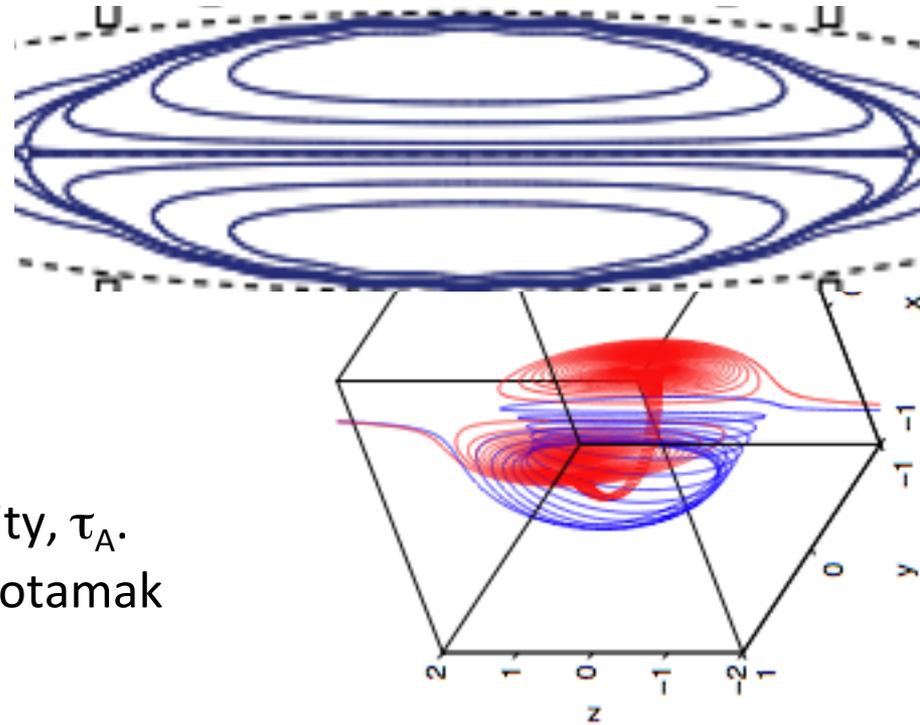

Even



Odd

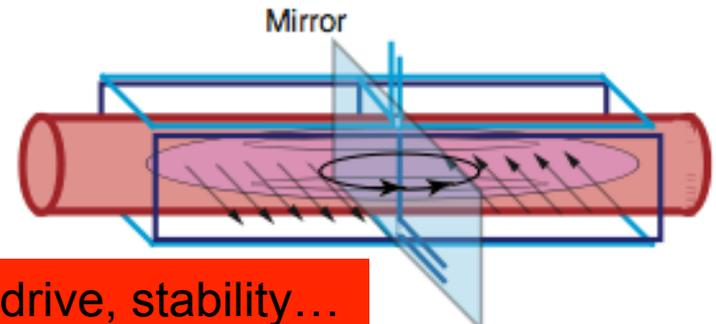
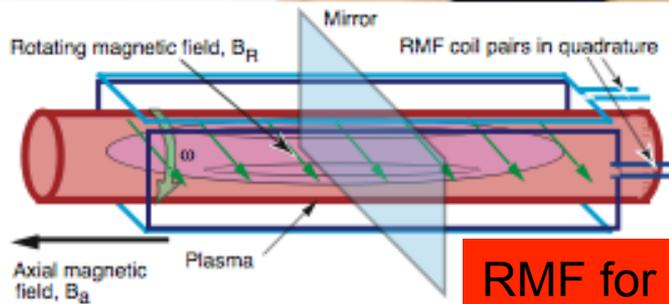

RMF for heating, current drive, stability...

Predicted to

1. Improve τ_E 
2. Maintain stability 
3. Cause ion heating
4. Cause electron heating 
5. Generate current needed to sustain the FRC 
6. Provide a means for direct energy extraction

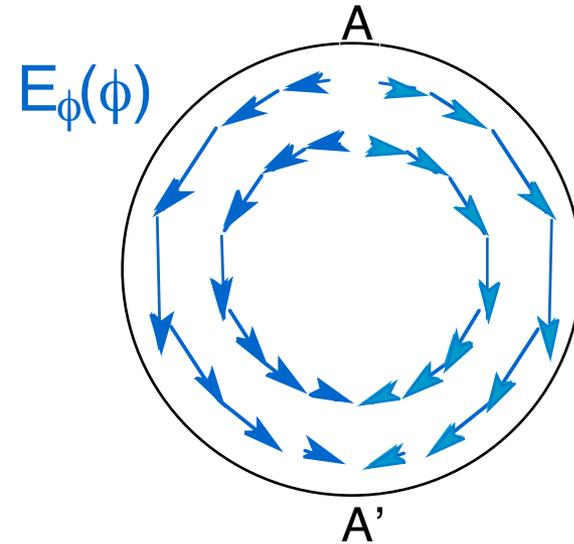

An odd-parity rotating *magnetic* field creates a rotating *electron* field on the midplane.

1. τ_E : better be better in *small* FRCs

- Smaller devices need lower transport coefficients, but ash must be exhausted.
- In tokamaks, transport is generally faster than neoclassical but has been seen to slow down for hot particles.
- Recent FRC work (TriAlpha) show near classical confinement.
- In the FRC $q = 0$, so classical transport is $\sim 10x$ slower than neoclassical.
- Reducing the free energy for microinstabilities is important for reducing transport. RMF₀.
- FRC' s lack of B_t inhibits toroidal feedback of fluctuations.

An experimental and theoretical research program to investigate

RMF₀ heating
of small FRCs

with the goal of reaching

stable

steady-state

plasmas

with fusion-relevant parameters

suitable for burning *aneutronic* fuels

Hydrogen plasma in the PFRC-1

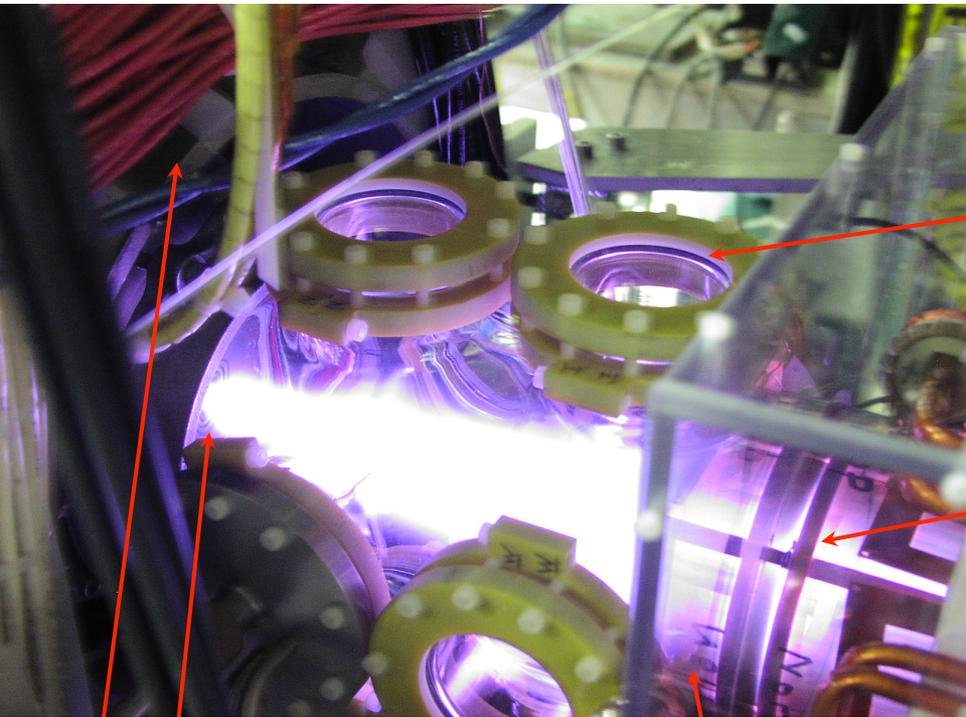

Quartz windows
viton sealed

Internal copper
flux conservers

Mirror coil

Main coil
(Helmholtz)

Multi-port
Pyrex vessel

Antenna
Rogowski
loops

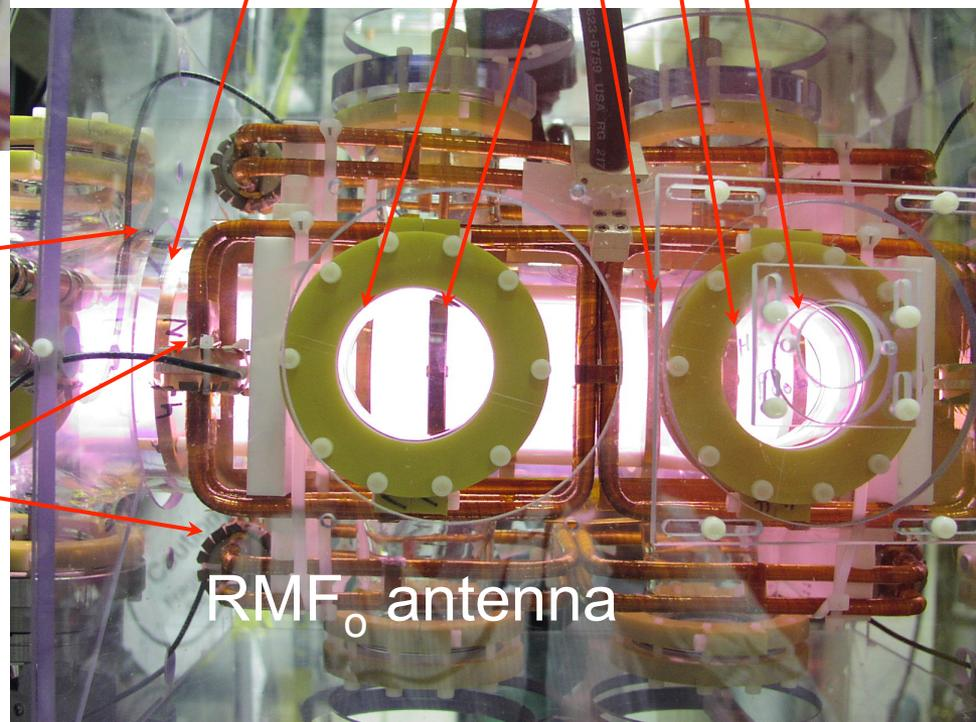

RMF₀ antenna

The PFRC-2

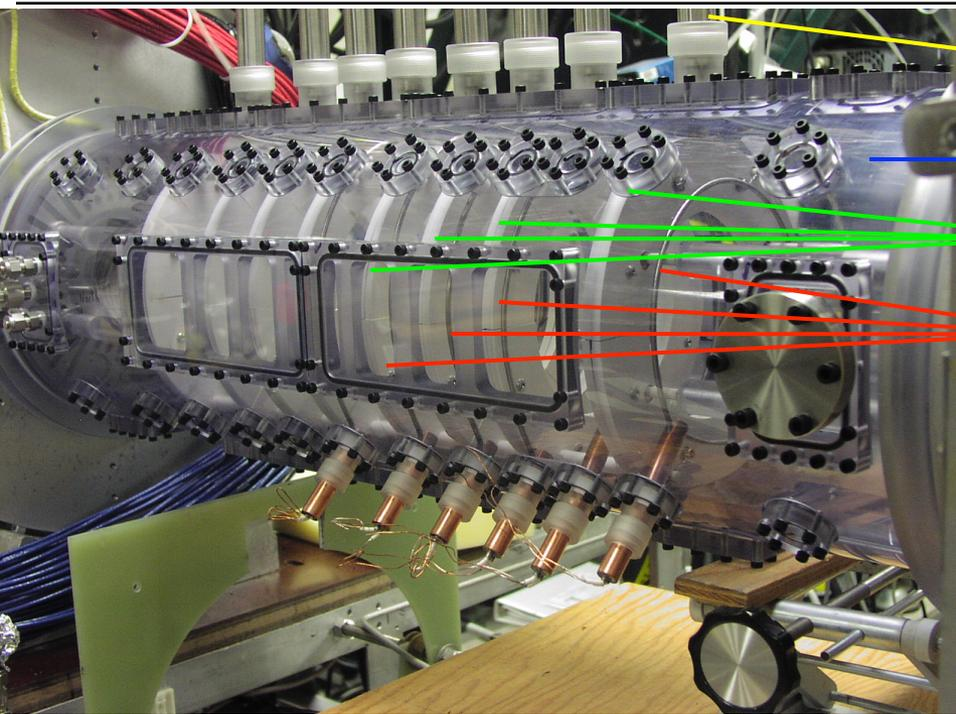
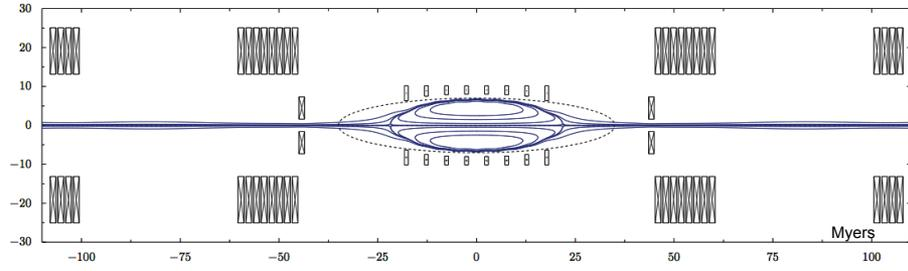

- Cryogenic feedthroughs
- Lexan vessel and port covers
- BN-covered *superconducting* FCs
(Myers, Edwards, Berlinger..)
- Diamagnetic loops

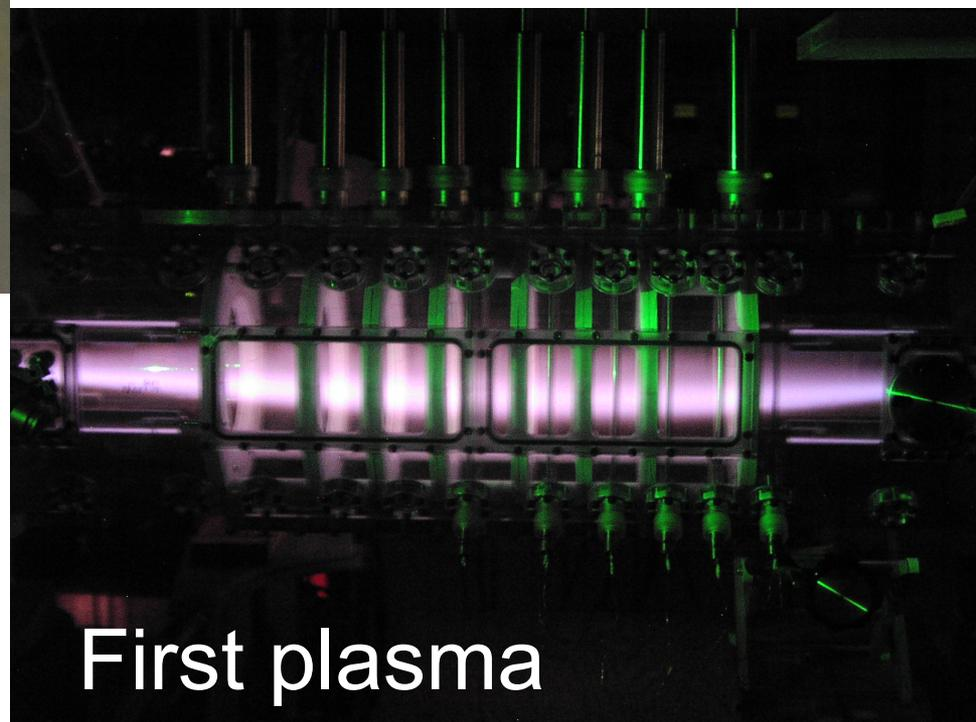

First plasma

Hamiltonian* for ion inside FRC

* Appropriate when collective effects are not

$$H = \frac{1}{2m} \left[p_r^2 + p_z^2 + \left(\frac{p_\phi}{r} - qA_\phi \right)^2 \right]$$

$$\mathbf{A} = B_a \frac{r}{2} \left(1 - \frac{r^2}{R^2} - \frac{\kappa^2 z^2}{R^2} \right) \hat{\phi}$$

$$\dot{q}_i = \frac{\partial H}{\partial p_i} \quad \dot{p}_i = -\frac{\partial H}{\partial q_i}$$

$$\text{Angular invariance } \dot{p}_\phi = -\frac{\partial H}{\partial \phi} = 0$$

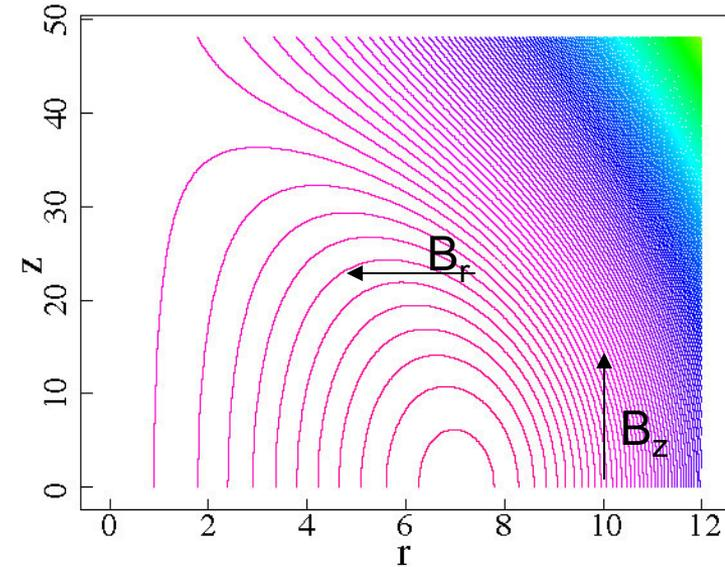

Solov'ev equilibrium
NO RMF

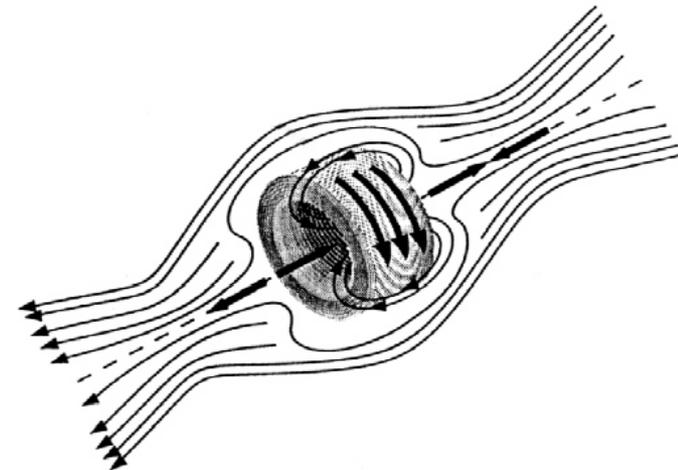

$$r / R \rightarrow r \quad z / R \rightarrow z \quad b = qB_a / 2$$

$$p_r / bR \rightarrow p_r \quad p_z / bR \rightarrow p_z$$

$$(m / b^2 R^2) H \rightarrow H \quad P = p_\phi / bR^2$$

- Rescaled Hamiltonian

$$H = \frac{1}{2} p_r^2 + \frac{1}{2} p_z^2 + V(r, z)$$

$$V(r, z) = \frac{1}{2} \left[\frac{P}{r} - r(1 - r^2 - \kappa^2 z^2) \right]^2$$

- Invariant subspace: $z = 0; \quad p_z = 0$

Three main classes of orbits

Cyclotron - drift clockwise (unstable), $P < 0.25$

Betatron - move counter clockwise (stable), $P > 0.25$

Figure 8 - mostly drift clockwise (mostly unstable), $P < 0.25$

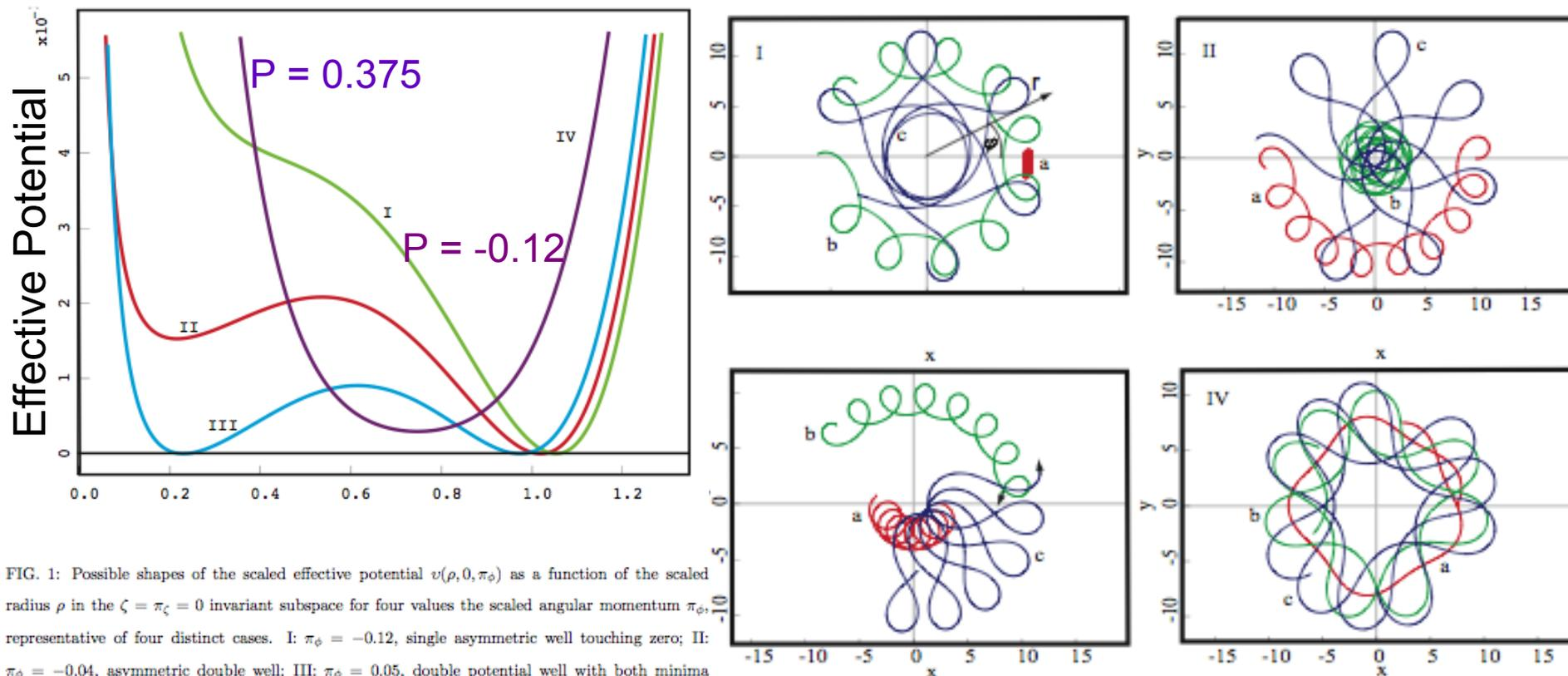
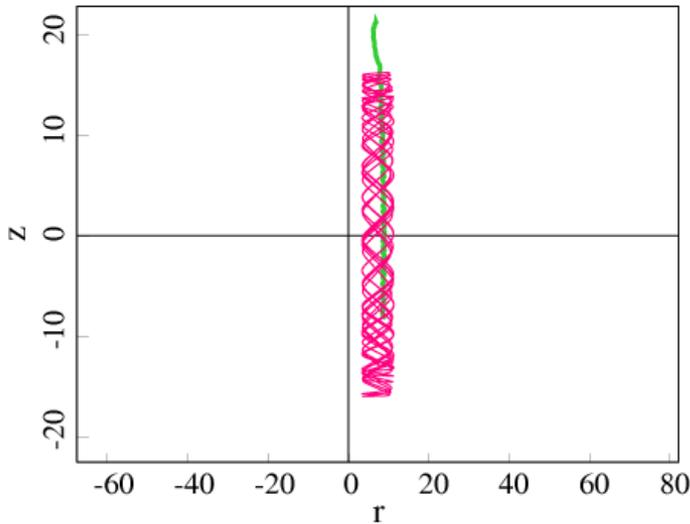

FIG. 1: Possible shapes of the scaled effective potential $v(\rho, 0, \pi_\phi)$ as a function of the scaled radius ρ in the $\zeta = \pi_\zeta = 0$ invariant subspace for four values the scaled angular momentum π_ϕ , representative of four distinct cases. I: $\pi_\phi = -0.12$, single asymmetric well touching zero; II: $\pi_\phi = -0.04$, asymmetric double well; III: $\pi_\phi = 0.05$, double potential well with both minima touching zero; IV: $\pi_\phi = 0.375$, raised potential well.

3. RMF_o ion heating (RMF code)

Orbit in Poloidal Plane



Orbit Viewed Along Z Axis

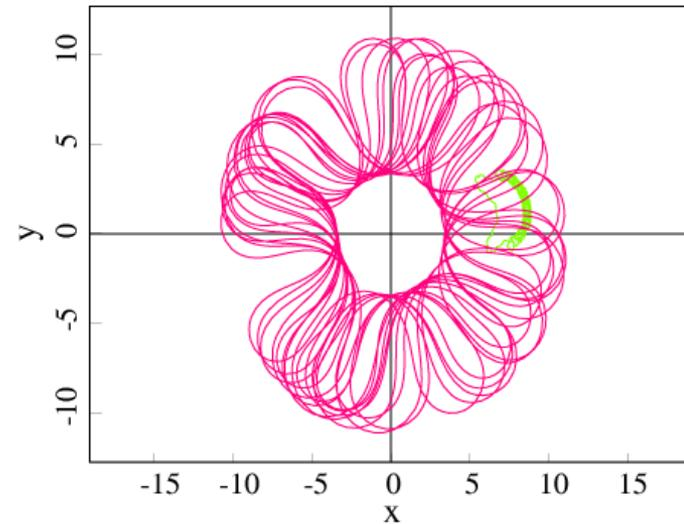

$B_o = 20 \text{ kG}$
 $B_R = 100 \text{ G}$
 $r_s = 10 \text{ cm}$
 $\omega_{RMF} = 0.8 \omega_{ci}$

Ion energy
 reaches fusion
 range in 0.01
 ms with no
 loss of
 confinement!

Axial Position

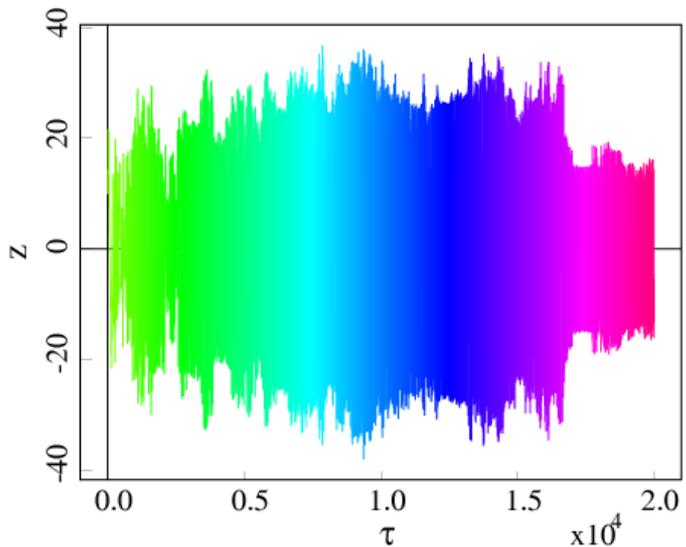

Kinetic Energy

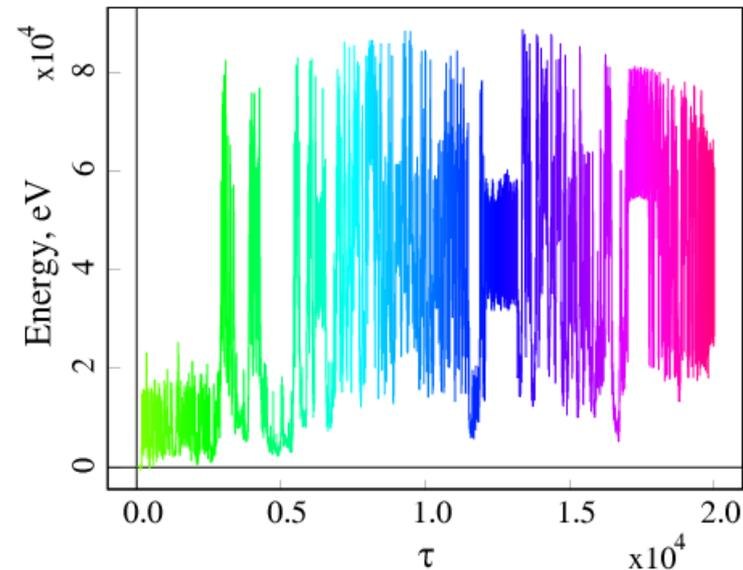

3. Predicted ion heating: $r = 10$ cm, $\kappa = 5$, $B_e = 20$ kG

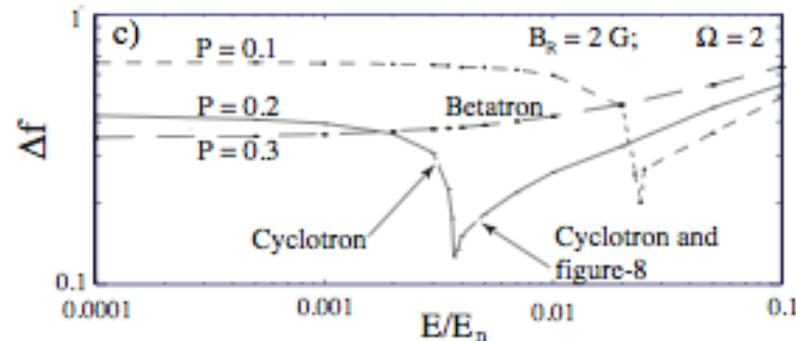
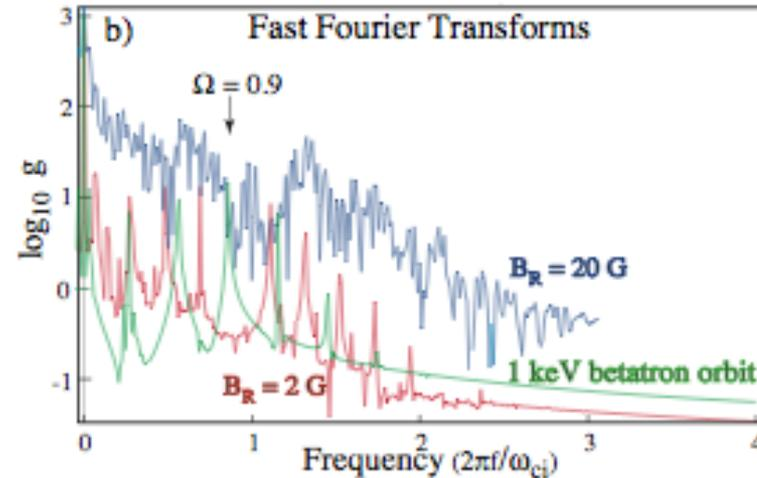
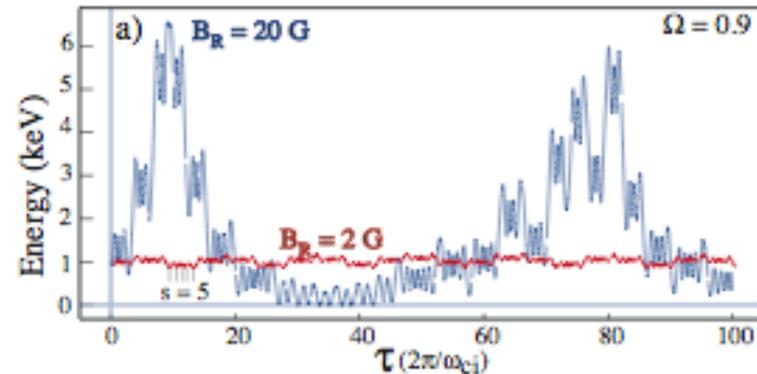
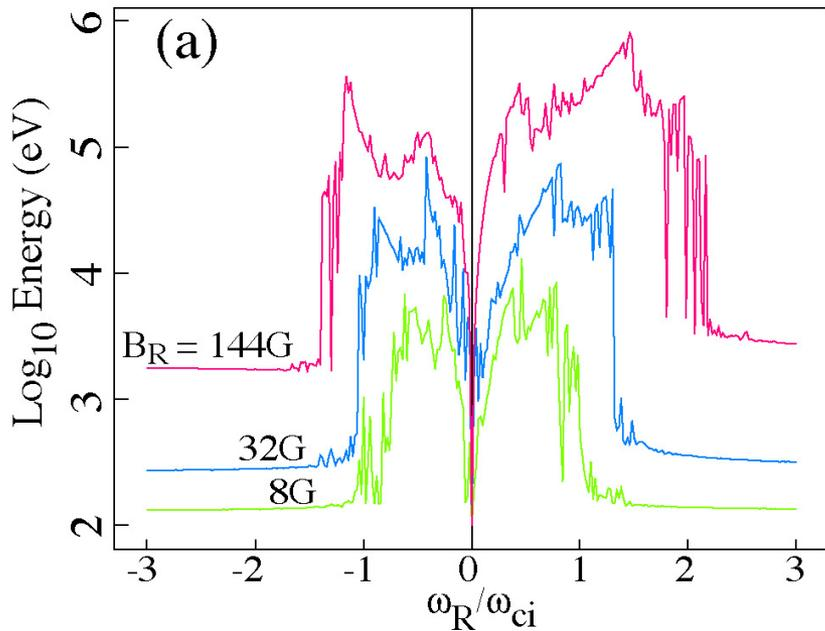

$$K_{odd} \approx 8\pi s \left(\frac{1}{kR} \right) \left(\frac{B_R}{B_a} \right) \frac{d\tilde{\omega}(\tilde{E})}{d\tilde{E}}$$

$$K_{even} \approx \frac{\pi}{2} s^2 (kR) \left(\frac{B_R}{B_a} \right) \frac{d\tilde{\omega}(\tilde{E})}{d\tilde{E}}$$

4. Electron heating (RMF code)

View along major axis

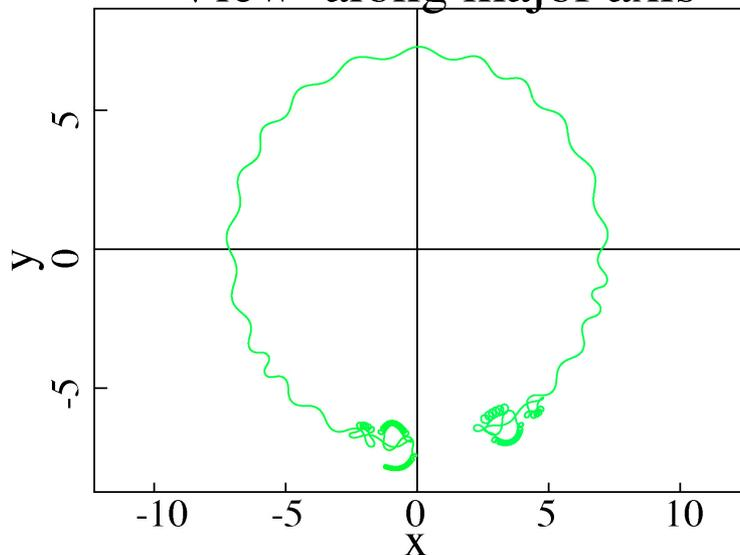

In rotating frame

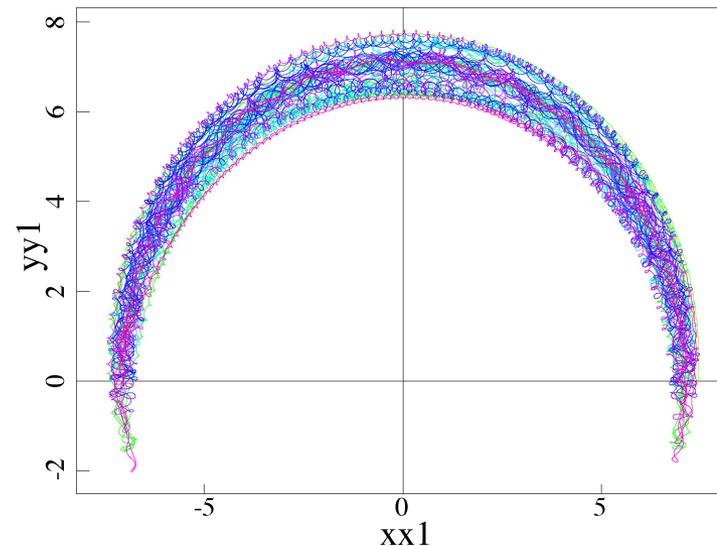

$B_0 = 20 \text{ G}$, $r_s = 10 \text{ cm}$, $\omega_{RMF} = 0.5 \omega_{ci}$

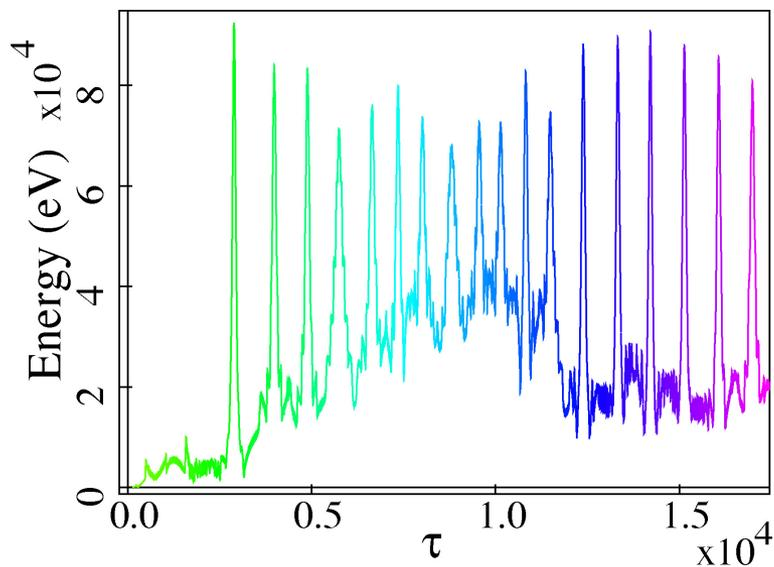

Histograms of Energy

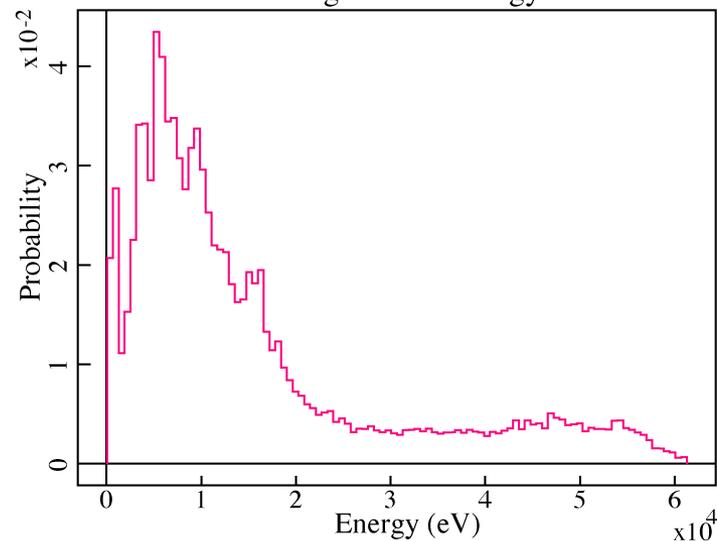

4. T_e from X-ray spectroscopy: Si PiN diode

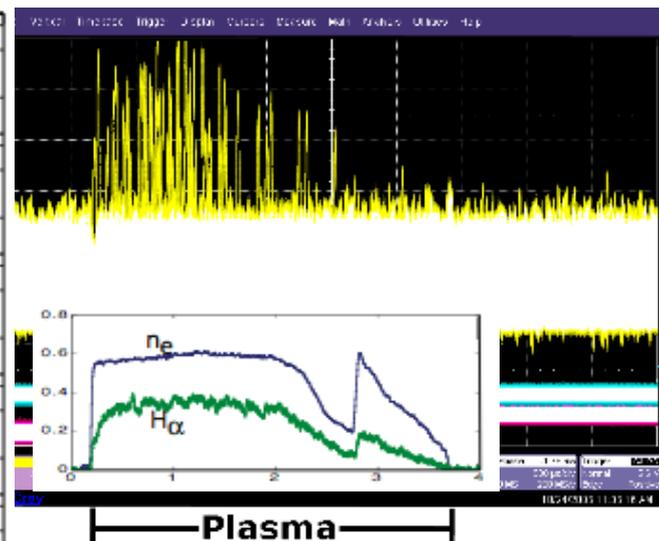
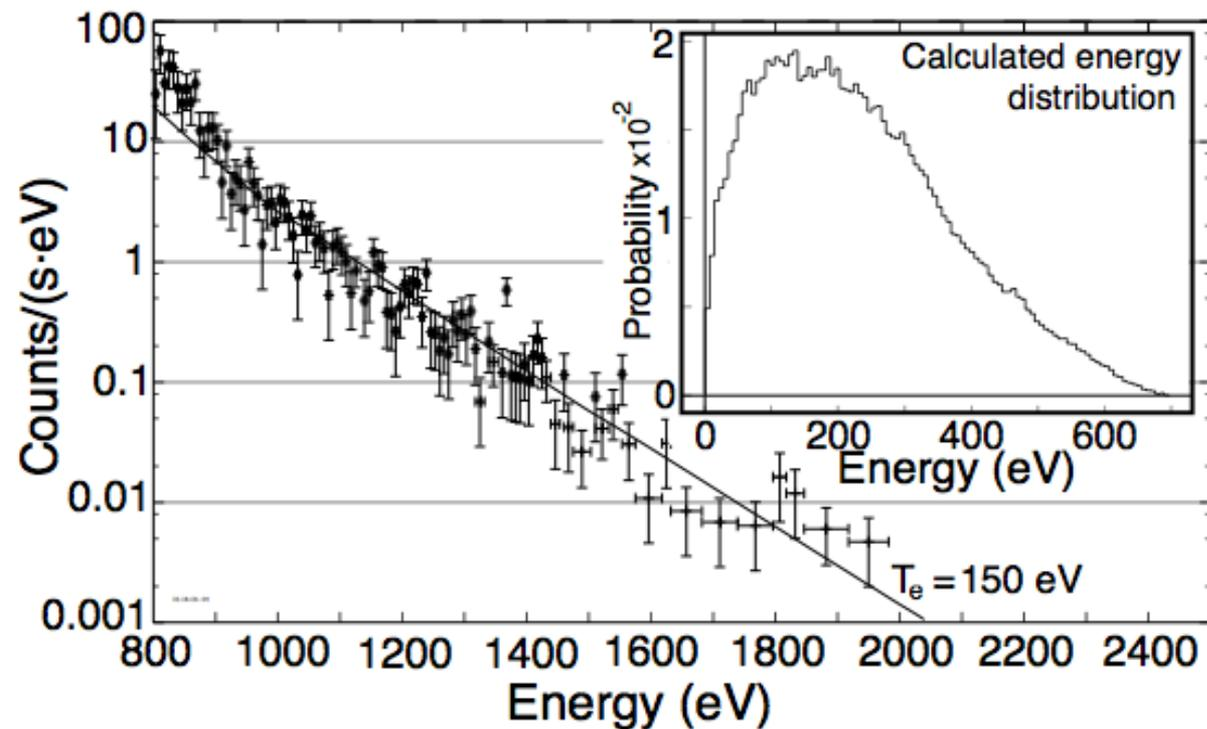

$P < 10$ kW

- Absolute X-ray brightness, I_B , higher than if due to $e^- + H^+$ collisions. Correlation of I_B with neutral density.
- T_e not readily measured late in discharge, at low neutral pressure: May be missing the highest average energy.
- Not seeing the truncated spectra *RMF* predicted!

4. Variety of X-ray spectra (PFRC-1)

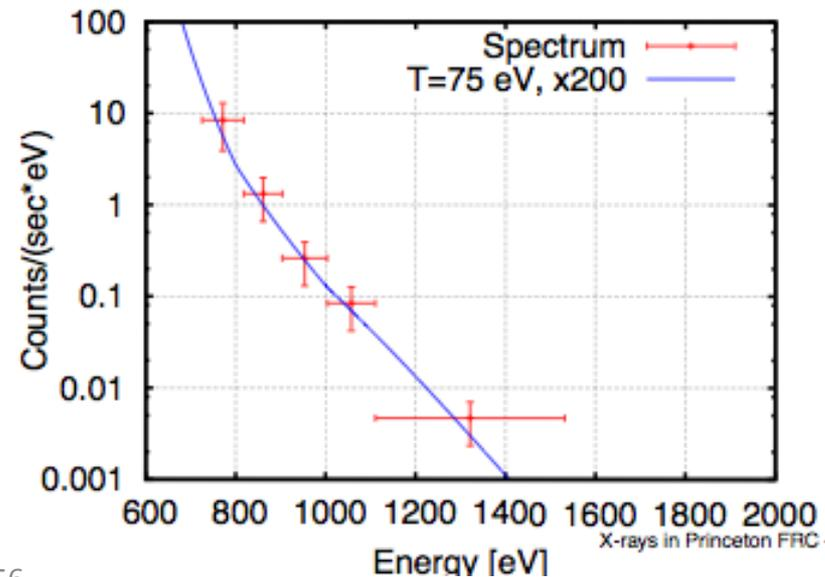
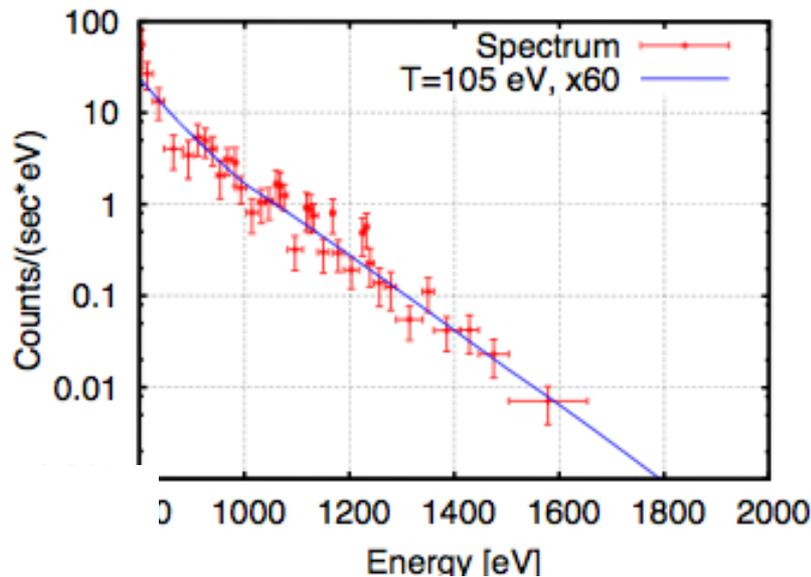
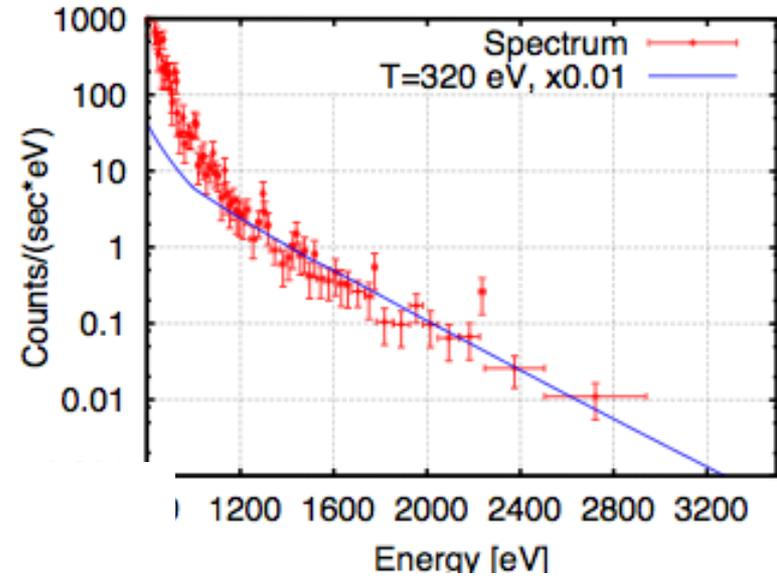
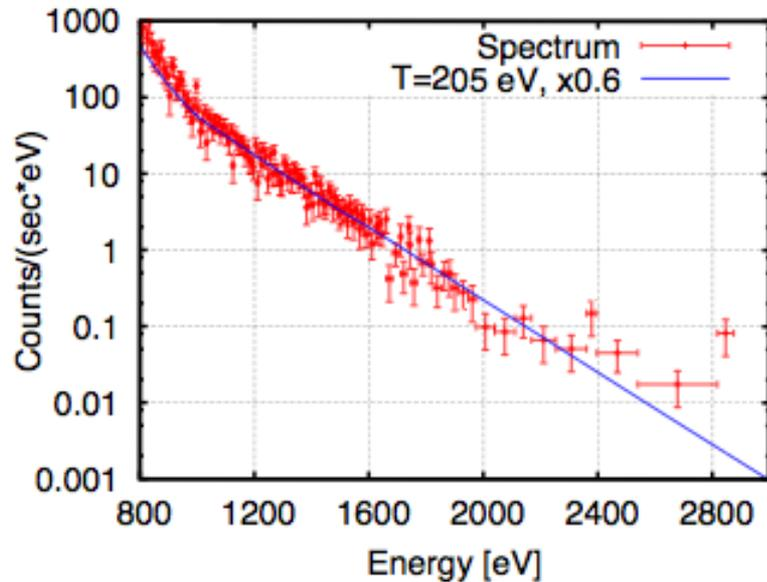

4. RMF₀ electron heating- Lsp (PIC) code

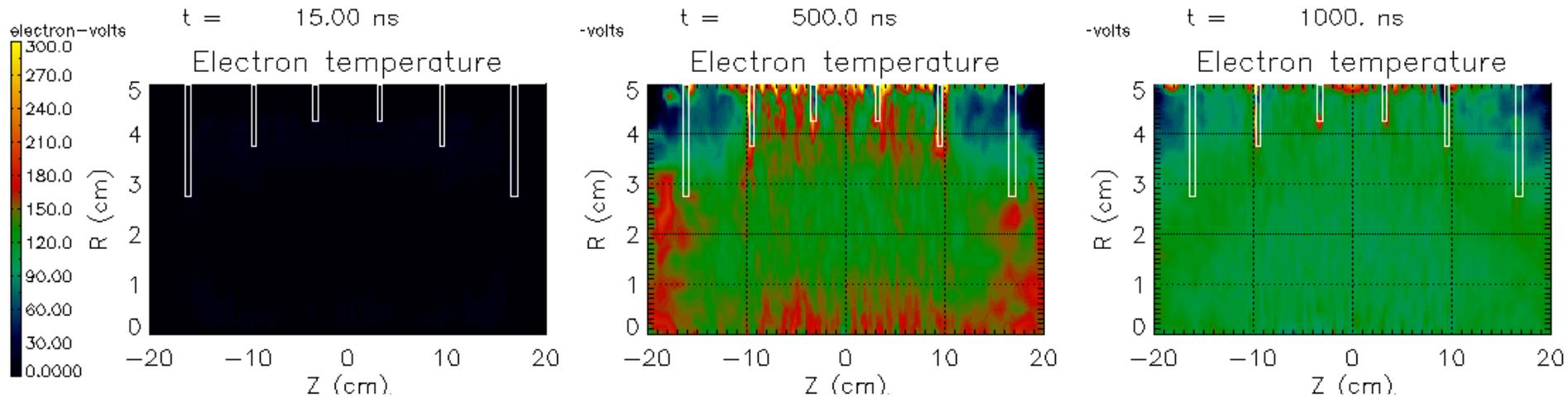

Fully self consistent, fully electromagnetic

LSP simulation between 120 and 150 eV Maxwellian, but with broader energy tail

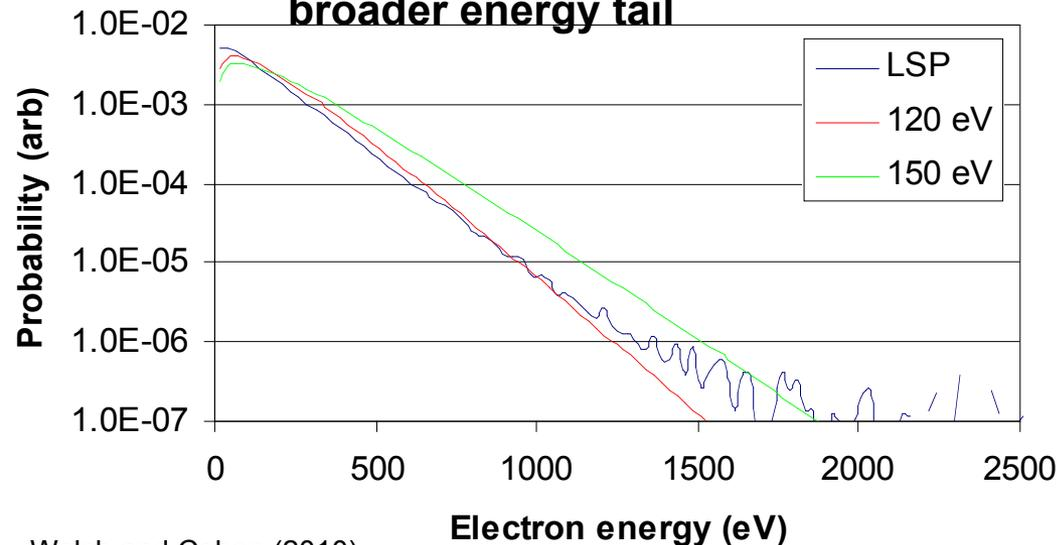

Welch and Cohen (2010)

PFRC Data showing 150-eV electron temperature

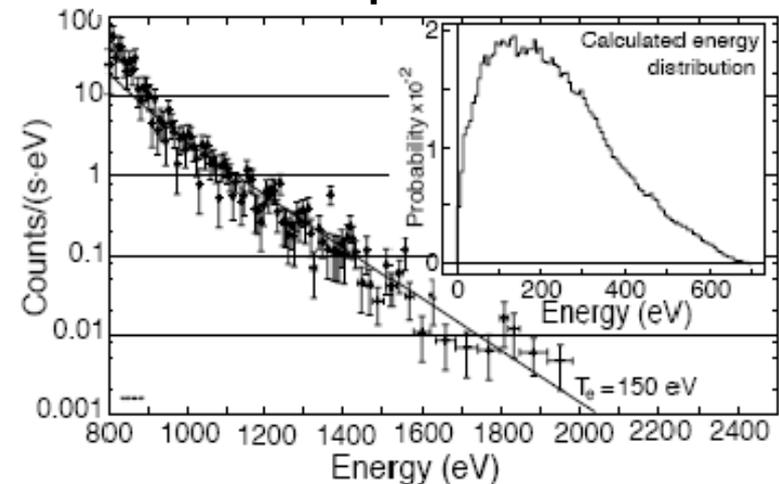

Roach and Cohen (2007)

5. Prediction: RMF_o drives current

Current drive is necessary for a steady-state reactor

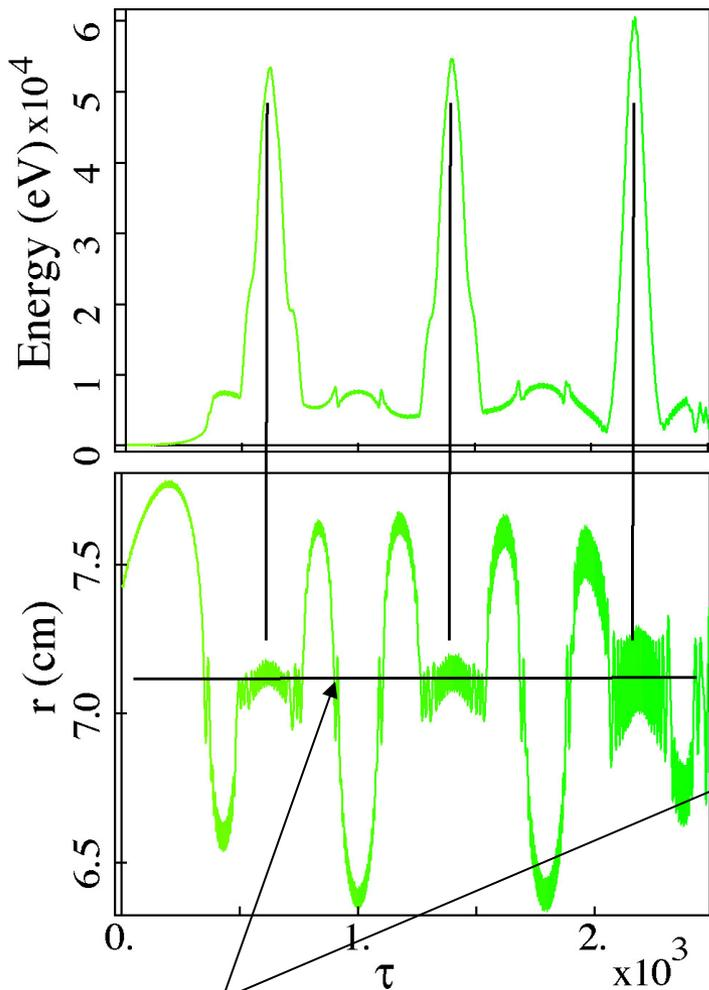

O-point
linelocation

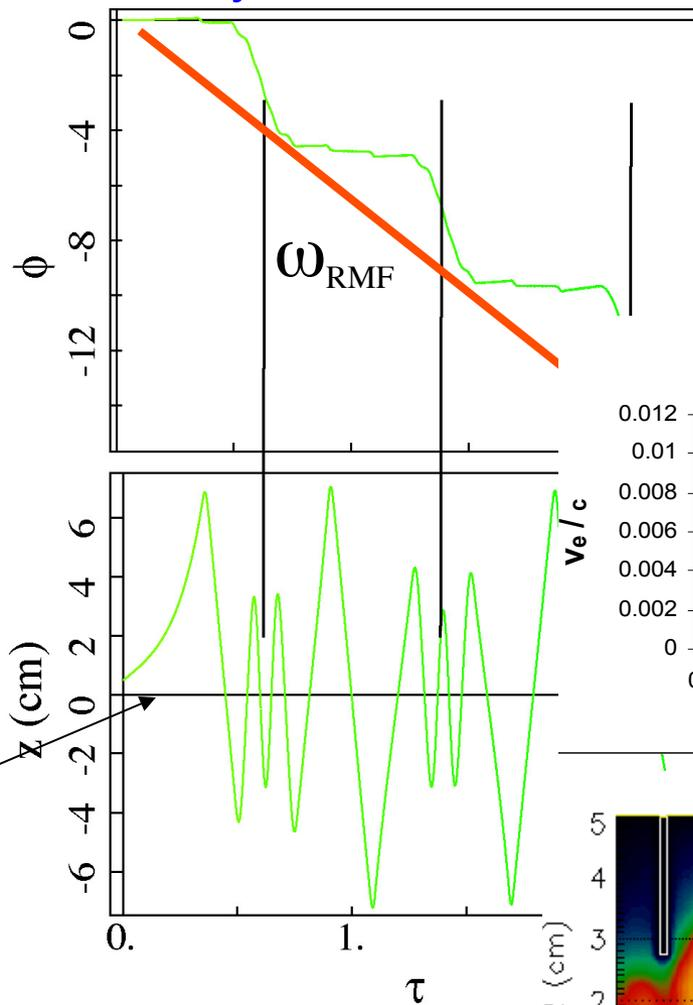

Welch and Cohen (PRL 2010)

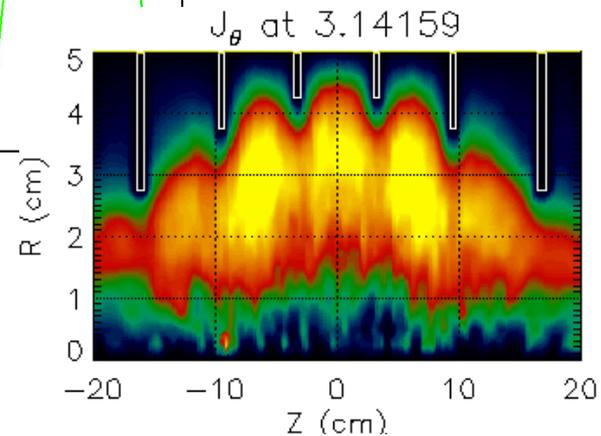
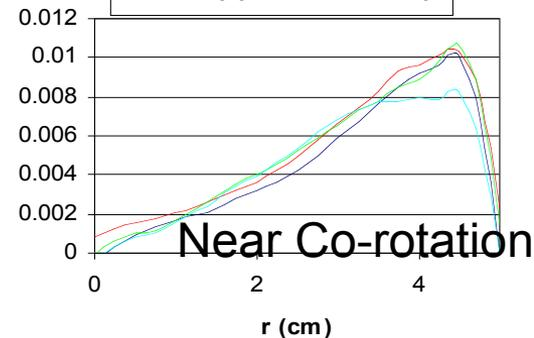

Evidence for closed magnetic field lines: PFRC-2

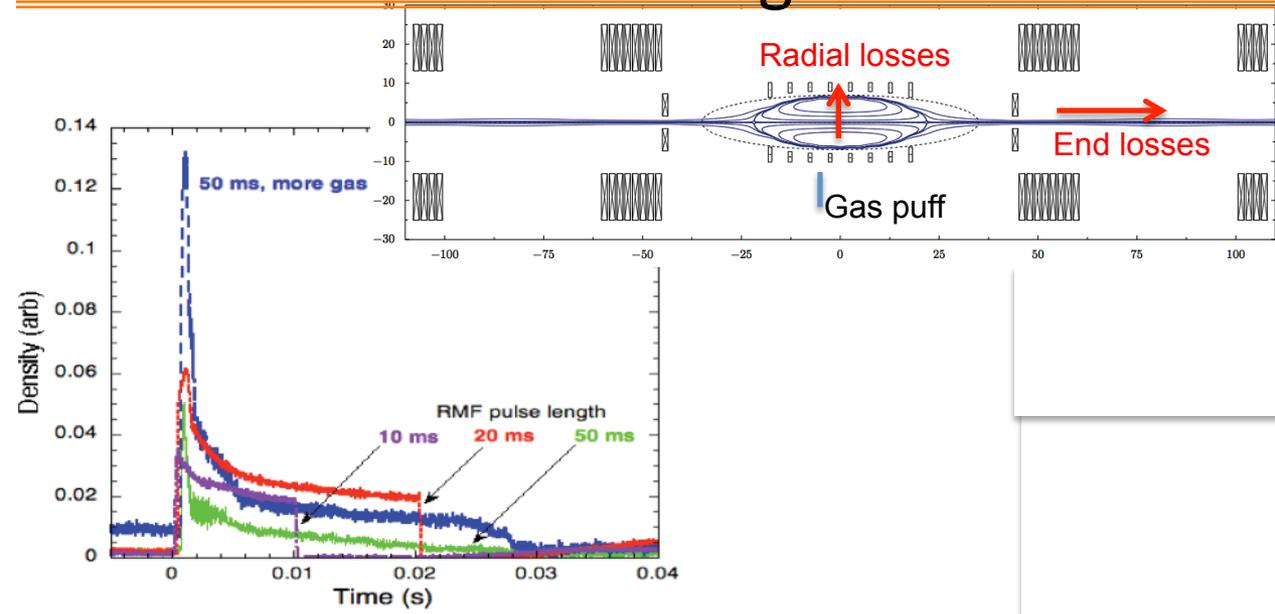

2 ms gas puff

- Promotes betatron orbits: good for current drive
» steady-state reactor
- Maintains field closure: good for confinement
- Generates truncated distributions: good for confinement
- Heats ions: good for fusion
- Heat electrons: good for current drive
- “Shakes” FRC up and down: good for stability
- Localizes ions near midplane: good for stability
- Other uses, too!

- RF controls
- Chamber design
- Energy extraction
- Fast ion losses
- Fuelling/fuel mix
- PMI
- Nuclear materials
- Lifetime
- Reliability

Reactor: point design

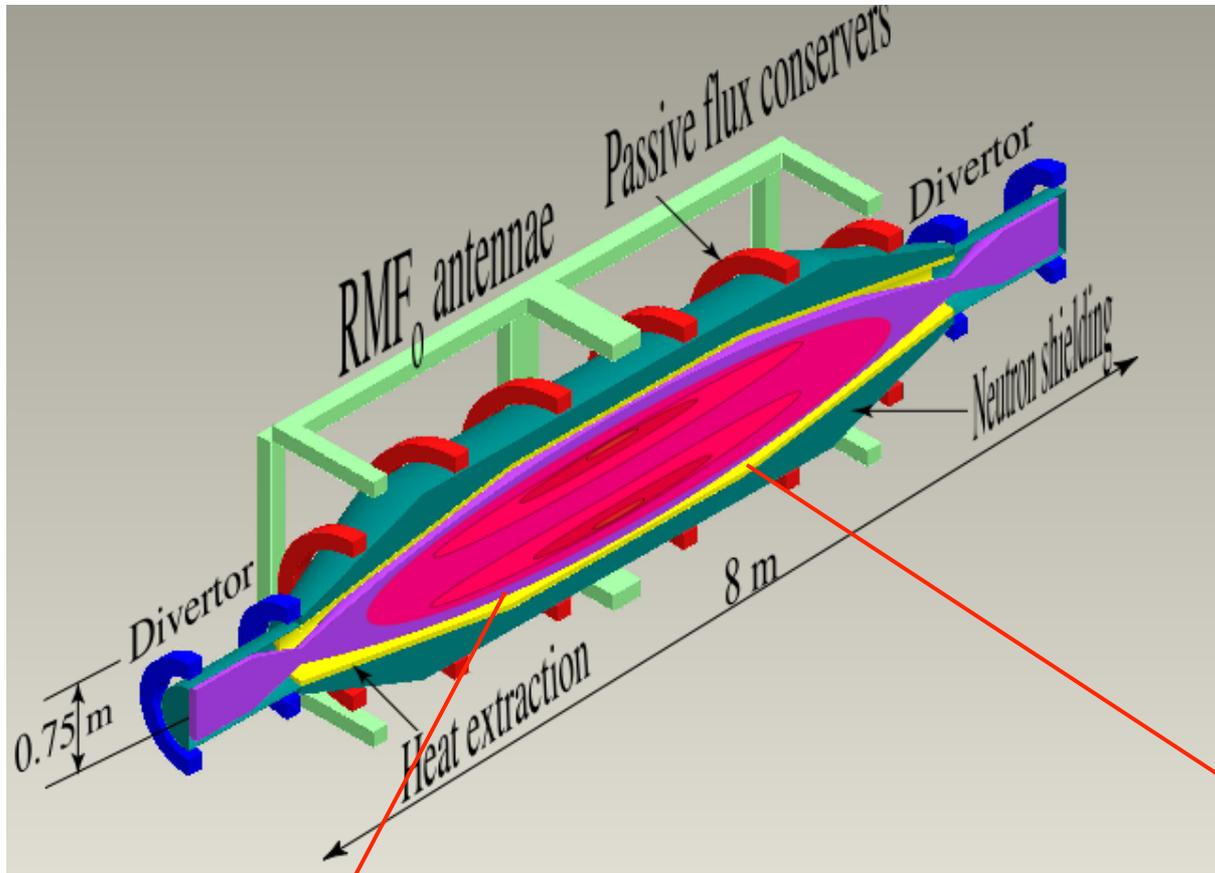

- $P_{\text{fusion}} = 5 \text{ MW}$
- $P_{\text{D-Dneutrons}} = 50 \text{ kW}$
- $n_e = 8 \times 10^{14} \text{ cm}^{-3}$
- $T_e = 60 \text{ keV}; \quad n_D = n_{\text{He3}}$
- $T_{\text{He3}} = 200 \text{ keV}$
- $T_D = 90 \text{ keV}$
- $P_{\text{RMF}_0} = 1 \text{ MW}$
- $P_{\text{Brems}} = 0.42 \text{ MW}$
- $B_a = 80 \text{ kG}$
- $B_R = 500 \text{ G}$
- $r_s = 25 \text{ cm}$
- $\kappa = 10$
- $t_{\text{shielding}} = 20 \text{ cm}$
- $\gamma/\lambda = 110 \text{ (RMF penetration)}$
- $\alpha = 0.02$

Prompt losses

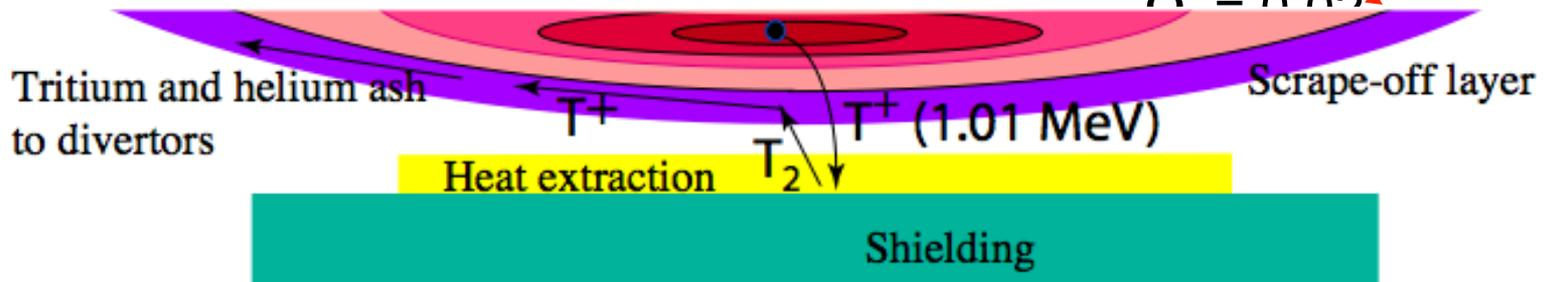

- If RMF₀ works its *many* wonders, reactor development and implementation could progress rapidly.
- He³ (fuel) availability will be an important question.
- Physics **CHALLENGES**: near classical τ_E ; stability·····.
- Physics research remains a rich and surprising field.
- Diagnostics are essential to judge and control performance.

The theory for RMF₀-heated FRCs points to **small clean** fusion reactors, capable of **rapid testing**, **improvement** and **implementation**.

Using **COTS** equipment, experimental tests of some RMF₀ theory, e.g., **electron heating**, have been very positive. Electron temperatures 8 x higher and collisionality 3000 x smaller have been attained in a device **10 x smaller** and with **0.1%** of the **heating power** than previous FRC/RMF devices.



Science & Space

[Home](#) | [Environment](#) | [Energy](#) | [Going Green](#) | [Space](#) | [Animals](#) | [Photos](#)

SPACE

Going to Mars via Fusion Power? Could Be

A high-speed, lightweight way to travel in space — provided someone can actually build the thing

By [Michael D. Lemonick](#) | Sept. 11, 2013 | [24 Comments](#)

At first, it's hard to know whether to take the company known as [Princeton Satellite Systems](#) (PSS) seriously. For one thing, the PSS offices, a few rooms in a nondescript building in nondescript Plainsboro, N.J., right above the Sugar and Sunshine Bakery, don't exactly suggest the imminent conquest of the final frontier. The company's ambitions, by contrast, certainly do — but those sound so crazy that you have to wonder if they're serious. This team of a half-dozen or so scientists and engineers is determined to send human beings to Mars, launch robotic probes to the outer solar system, send missions to Alpha Centauri and more, and do it all with rockets powered by nuclear fusion.

You heard that right: fusion. It's the energy source that makes stars shine and that plasma physicists have been trying to tame for more than 50 years — so far, despite [ever more gigantic and expensive machines](#), in

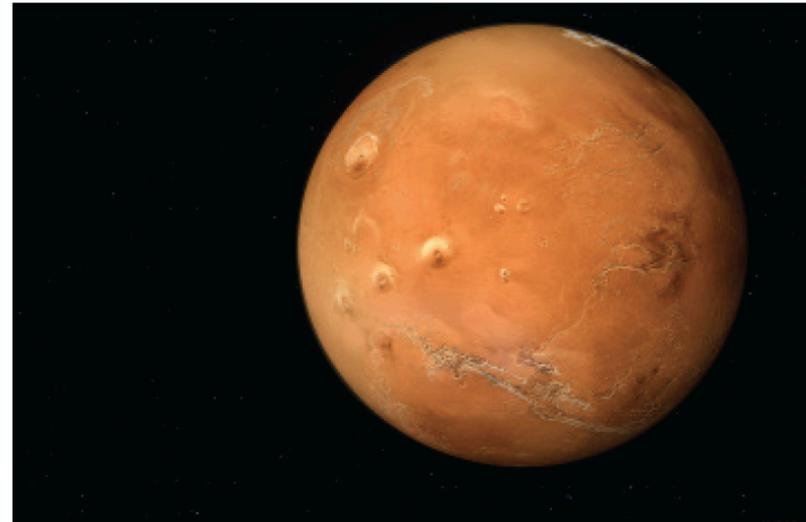

Getty Images

Why ^3He ?

- ◆ Far less neutron activation of & damage to structure.
- ◆ Less shielding required.
- ◆ No tritium breeding required.
- ◆ Materials development/testing would be far less demanding than for D-T.

How low can the neutron generation rate be made without sacrificing power density?

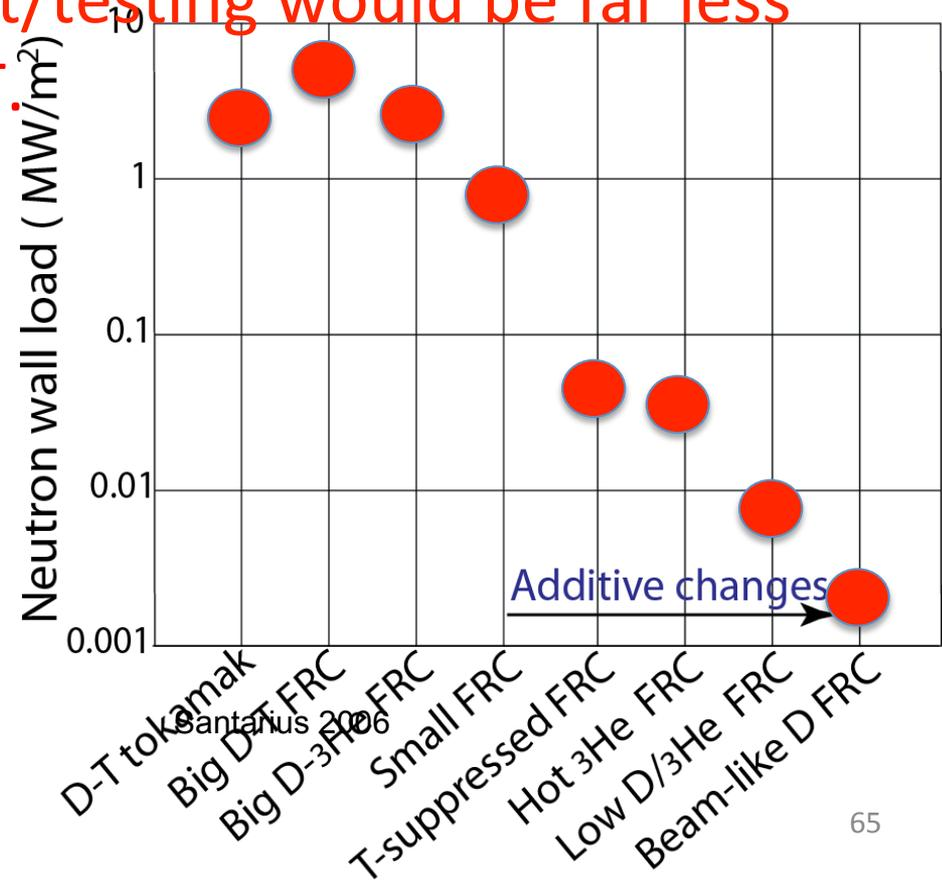

How much Terrestrial helium-3?

Update of Wittenberg, Santarius, Kulcinski

Inventory from T decay

US (Savannah River, Watt's Bar)

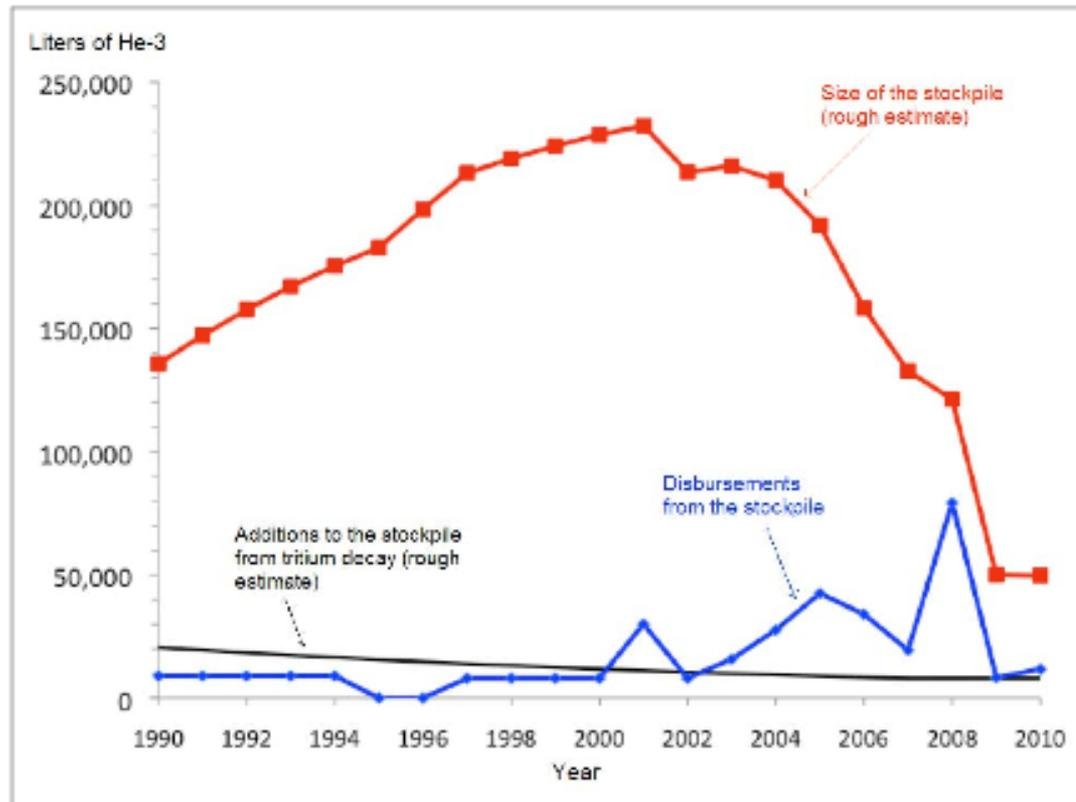

Summary of Earth's Potentially Accessible He-3 Supply

Approximate Current Inventory(L)	Annual Production Rate (L/year)	Current Form (S-separated, NS-mixed)	Location	Source	Ref.
31,000	8,000-10,000	S	Savannah River Site	Decayed tritium of nuclear weapons stockpile	[1]
100,000	10,000	NS, w/ tritium	Ontario Power Generation	Decayed tritium from heavy water reactors	[1]
125,000		NS, w/ 4He	Amarillo, Texas	Natural helium gas in earth	[1]
200,000		NS, w/ 4He or natural gas	Wyoming	Natural helium gas in earth	[1]
1500	8,000-10,000 every 8-10 years	NS	National labs; Savannah River's TEF	Unused equipment and supplies; retired tritium beds	[1]
undisclosed	undisclosed	NS, w/ tritium	Russia, India, South Korea	Decayed tritium	[1],[4],[7]

Accessible ^3He \sim accessible ^3H

If we started burning ^3He in 10 years,
it would fuel 10-30 5-MW reactors.

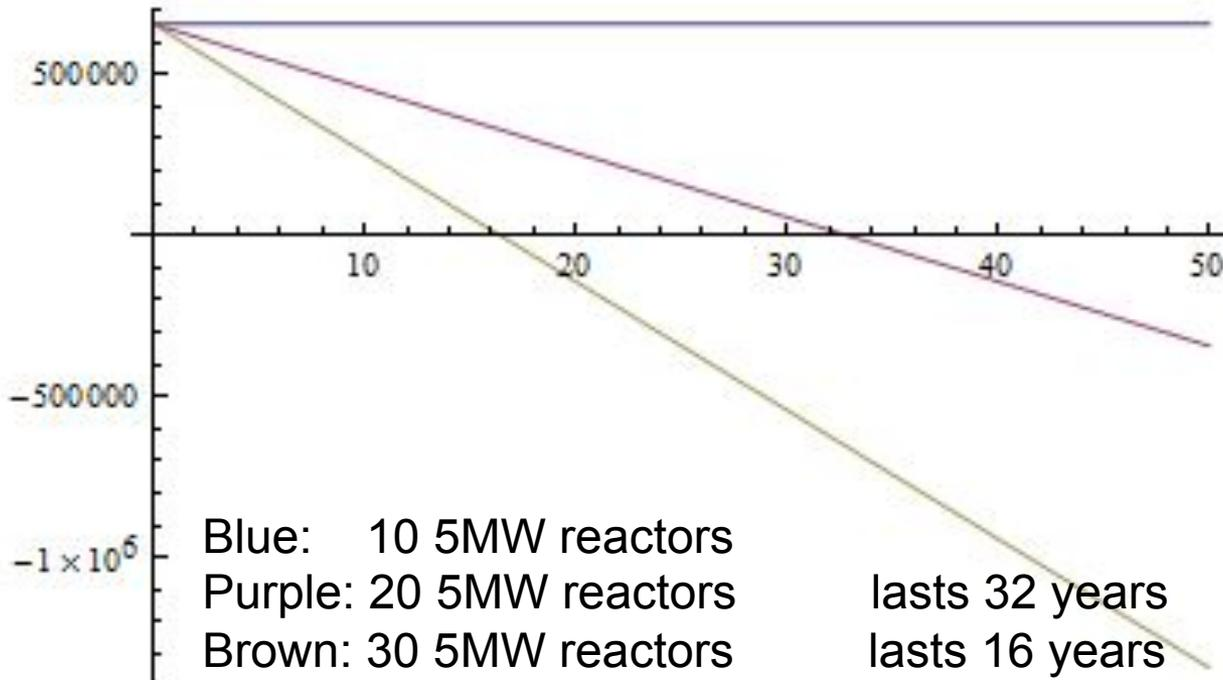

Small D- ^3He fueled reactors would not have to worry about T breeding.

1. Needs higher beta, 0.2-0.5 instead of 0.05.
2. Needs stronger magnets, to 30 T.
3. Too big – would consume entire ^3He inventory less than one month into full power operation.
4. Steady-state heat load on divertor is x5 higher than for D-T. (D. Whyte)
5. Needs 5x shorter τ_{ash} than D-T. (No demonstrated method for eliminating T ash.)
6. Higher synchrotron radiation losses are bad for τ_E .
7. Higher plasma stored energy (at higher B and β) will make heat loads from disruptions even higher.

Start within this ${}^3\text{He}$ -availability boundary by developing 5-MW D- ${}^3\text{He}$ reactors so we can experiment with them, improve them, and even *USE* them for making power or propelling spacecraft.

THEN investigate He-catalyzed D-D reactors, which eliminate the need to mine the moon or breed tritium in blankets and, most importantly, allows for **far greater electricity production**. The penalty is a higher neutron load, which depends on how much of the ${}^3\text{He}$ produced is burned in that reactor. The required plasma confinement time is about three times that as for D- ${}^3\text{He}$ if no ${}^3\text{He}$ is burned.

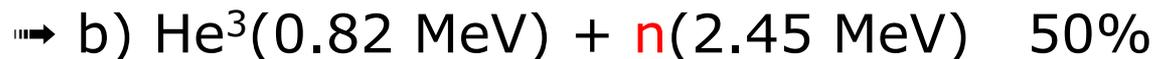
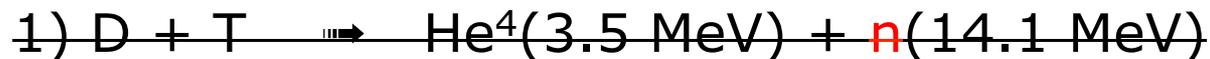

Two plant model: FRCs



12 years

${}^3\text{He}$

${}^3\text{He}$



Parameter	Pure D-D	D-He3
r_s (cm)	30	25
kappa	7	7
B_a (T)	8.7	7
ω_{RMF} (10^6 rad/s)	1.4	1.6
$\omega_{\text{RMF}} / \omega_{\text{ci}}$	0.004	0.005
n_e (10^{14} cm^{-3})	7	7
T_e (keV)	20	30
T_i (keV)	200	125
Φ (Wb)	0.46	0.22
τ_E (s)	39	5
S^*/kappa	3.5	2.9
$\gamma_d = v_{\text{de}}/v_{\text{ti}}$	0.015	0.02
RMF penetration	24	73
CD efficiency (A/W)	19.3	12.9
${}^3\text{He}/\text{D}$	/	3
P_f (MW)	10.1	7.1
P_{Bremms} (MW)	0.92	1.2
P_{Synch} (MW)	5.2	2.9
P_{RMF} (MW)	1	1
Electrical power out (MW)	2.2	4.1
Confinement/classical	0.85	0.33
% power in neutrons	34	0.9

A New Vision for Fusion Energy Research: Fusion Rocket Engines for Planetary Defense

